



Hucktainer[®] For Metal-Clad Polymer Core Composite and Fiberglass Reinforced Panel Structures

Weather Resistant
Installs in Seconds
Corrosion Resistant



Hucktainer®

Bringing Huck® Quality to Composite Panel Assemblies for Trucks and Trailers

Hucktainer® has earned its reputation as the fastener of choice to provide consistent, controlled clamp, superior vibration resistance and fast, foolproof installation in truck trailers, truck bodies, cargo containers, and other structures fabricated from multi-ply composite panels.

The Hucktainer installs with consistent pressure, reducing the potential for crushing or crazing FRP panels and metal-clad applications. Each Hucktainer features a heavy zinc plating that resists corrosion. For even greater anti-corrosion protection, plastic encapsulation is available. The option of custom colors offers fade-resistant protection, while an integral double seal helps keep the elements and other contaminants from invading the joint.

Requiring only a few seconds to install, Hucktainer fasteners reduce assembly time. Unlike impact wrenches, the tools used to install Hucktainer fasteners come in your choice of air-powered or hydraulic models. Comfortable, ergonomically designed grips combined with easy-to-pull triggers minimize muscle strain and the possibility of repetitive-stress syndrome.

Hucktainer is now also available in shorter lengths called Hucktainer MC, specifically designed to accommodate stack-ups associated with metal-clad panels as thin as 3/16" (187).



Hucktainer Benefits

- Fast, quiet, foolproof installation
- Installs with consistent pressure, reducing crushing or crazing
- Spiral lock system, breakaway pintail, and smooth bore sleeve
- Heavy zinc plating resists corrosion
- Integral seal keeps contaminants from invading joint / weather-resistant
- Can never be over-torqued or under-torqued
- Tamper-resistant
- Custom coloring for encapsulations available
- Shorter grips available for today's thin metal-clad panels
- RoHS compliant



Installation Sequence

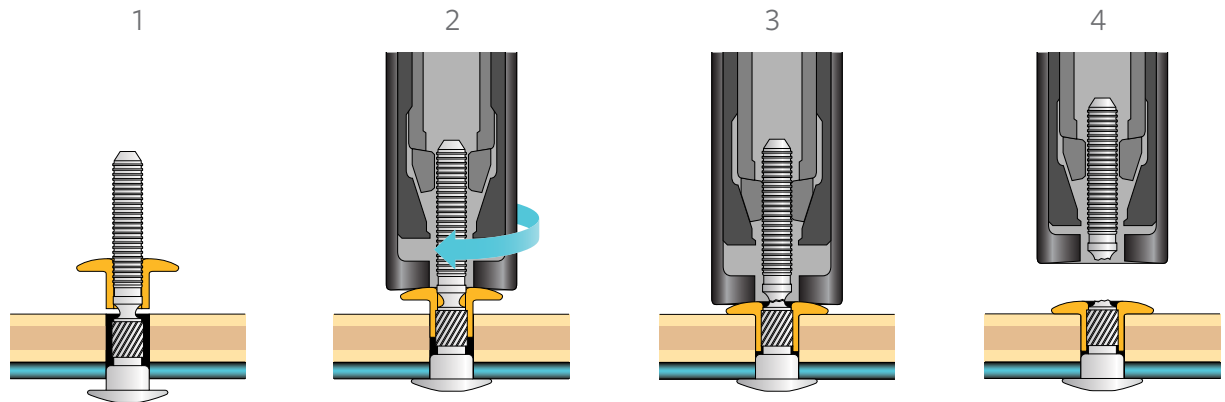

1
The pin and sleeve are inserted into the prepared hole.

2
The installation tool is applied to the pintail. When the tool is activated, the sleeve is forced onto the spiral lock of the pin. The rotating action of the nose assembly allows the sleeve to turn freely.

3
The sleeve is fully engaged on the pin and locks onto the pin's splines to clamp the material tightly together.

4
Continued pull of the tool causes the pintail to break away, which completes the installation cycle.

Secure, Fast Installation

1. Lower profile head design saves cargo space
2. Heads may be plastic-encapsulated for maximum corrosion-resistance; UV-resistant head encapsulation are colorfast and won't fade
3. Integral weather-resistant seal provides protection from the elements
4. Heavy-zinc plating protects against corrosion and preserves appearance
5. One sleeve fits all pins; no need to mix and match

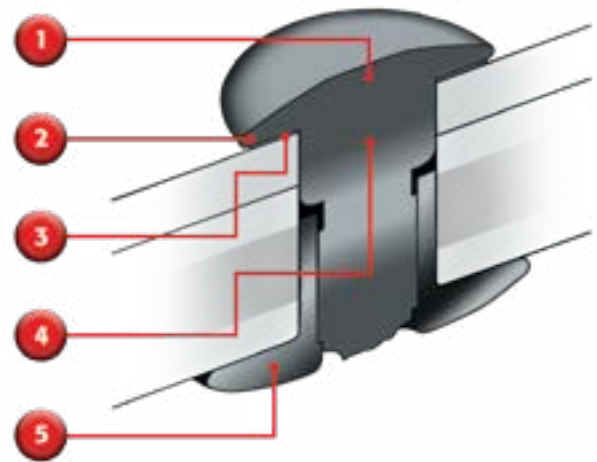

Direct-Tension Installation

Conventional threaded fasteners may only engage a few threads when joining thin sheets, allowing panels to separate in response to vibration. By contrast, Hucktainer's unique, direct-tension installation process provides for consistent clamp, ensuring accurate tension and a secure, durable connection, time after time.

Hucktainer MC

Same High Performance for Today's Ultra-Thin Material

Hucktainer has been re-engineered to accommodate thinner stack-ups associated with metal-clad (MC) panels in truck and trailer assemblies. Like original Hucktainer, Hucktainer MC utilizes proprietary Huck technology, helping Hucktainer deliver both clamp and vibration resistance that can't be matched by conventional threaded fasteners.

Hucktainer MC also features an encapsulated head which forms an integral seal that helps keep the elements and other contaminants from invading the joint, and preserving good looks. If corrosion-resistant fasteners are not used in trailer body assembly, the chance of water damage significantly increases. Over time, this can affect joints and the surrounding metal-clad panels.

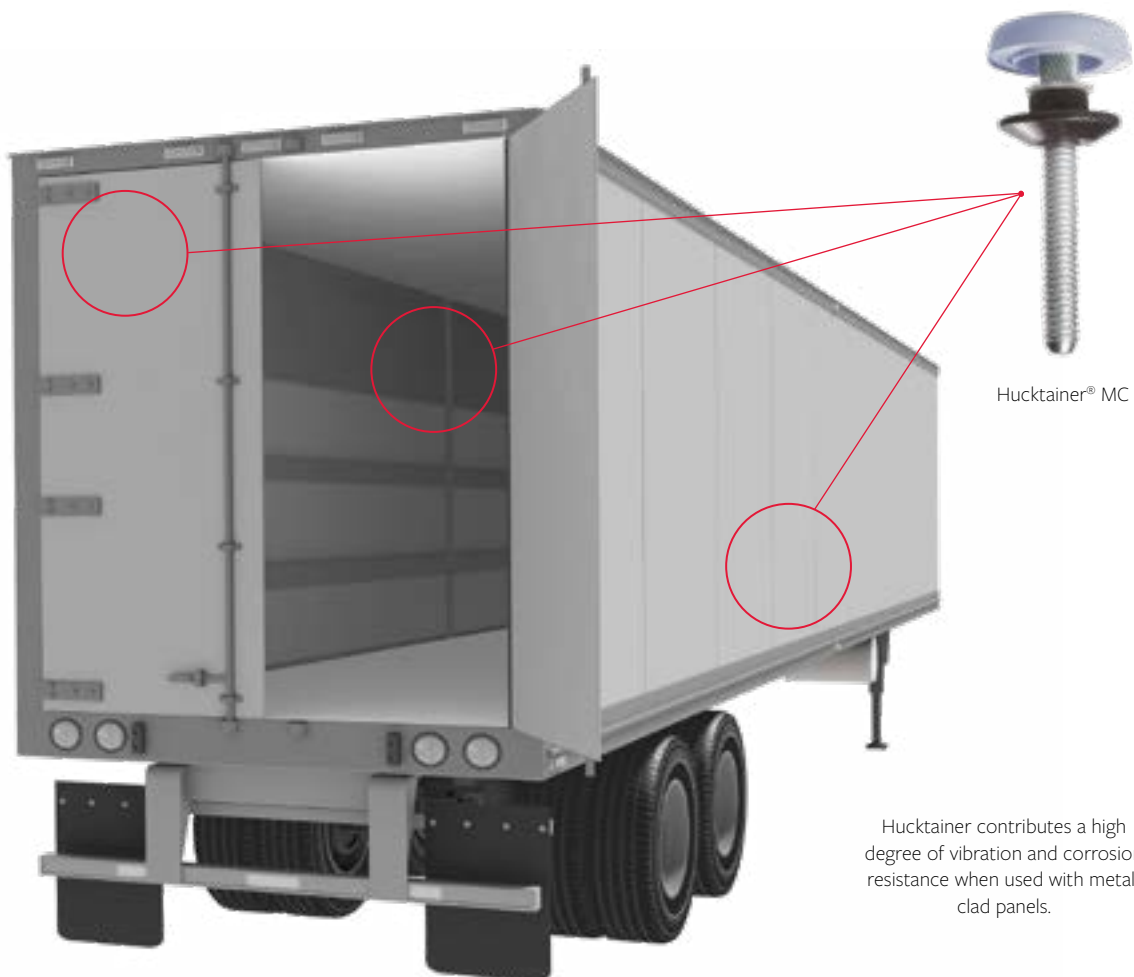

Data and Dimensions

Metal Clad HLP				
GRIP NO.	GRIP RANGE		A	B
	MIN	MAX		
-4 ¹	.187	.312	.338	1.993
-5	.250	.375	.400	2.055
-6	.312	.437	.462	2.118
-7	.375	.500	.525	2.180
-8	.437	.562	.588	2.243
-9 ²	.500	.625	.650	2.305

Standard HLP				
GRIP NO.	GRIP RANGE		A	B
	MIN	MAX		
-9 ³	.500	.625	.562	2.170
-10	.562	.687	.624	2.232
-11	.625	.750	.687	2.295
-12	.687	.812	.749	2.357
-13	.750	.875	.812	2.420
-14	.812	.937	.874	2.482
-15	.875	1.000	.937	2.545
-16	.937	1.062	.999	2.607
-17	1.000	1.125	1.062	2.670
-18	1.062	1.187	1.124	2.732
-19	1.125	1.250	1.187	2.795
-20	1.187	1.312	1.249	2.857
-21	1.250	1.375	1.312	2.920
-22	1.312	1.437	1.374	2.982
-23	1.375	1.500	1.437	3.045
-24	1.437	1.562	1.499	3.107
-25	1.500	1.625	1.562	3.170
-26	1.562	1.687	1.625	3.232
-27	1.625	1.750	1.687	3.295
-28	1.687	1.812	1.750	3.357
-29 ⁴	1.750	1.875	1.812	3.420

Materials and Finishes		
	MATERIAL	FINISH
METAL-CLAD HLP		
SLEEVE	STEEL	ZINC/BLACK CHROMATE
PIN	STEEL	ZINC/CLEAR CHROMATE
STANDARD HLP		
SLEEVE	STEEL	ZINC/GOLD CHROMATE
PIN	STEEL	ZINC/CLEAR CHROMATE

Tensile (lbf)	
METAL-CLAD HLP	
MINIMUM GRIP	1600
MID GRIP	1000
MAXIMUM GRIP	600
STANDARD HLP	
MINIMUM GRIP	1800
MID GRIP	1200
MAXIMUM GRIP	800

Recommended Hole Size	
HOLE DIAMETER	.405-.421

NOTE:

Only wide bearing pin HLPSCGE() and/or wide bearing sleeve HLPSCG should be used directly against FRP. Consult factory for stock status; minimums may apply. Available only in encapsulated configuration.

¹ Available encapsulated only.

² For encapsulated - 9 see STD HLP.

³ For unencapsulated see HLPSCM.

⁴ Not available encapsulated.

All dimensions are in inches.

Color Pin Locks

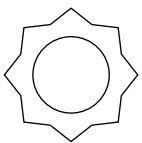

All HLP's now come standard with a pin lock, which assists in a semi-one-side installation. That is, it helps to keep the pin in the hole while placing a sleeve over the pintail. It also keeps the pins from falling back through from the shock of their neighboring fasteners being installed.

Now you can get pin locks that are color coded to help identify specific grip lengths of loose fasteners from a distance.

Currently the color coded pin locks are only available on HLPSCM products. All standard HLP pins have white pin locks.

HLPSCM Pin Lock Colors

	-4
	-5
	-6
	-7
	-8
	All other grip numbers

Recommended Installation Configurations

Metal-Clad

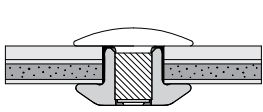

HLMC-R12- () and HLMCS-R12

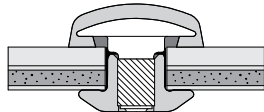

HLMC(*)-R12- () and HLMCS-R12

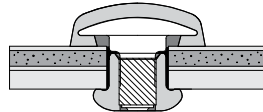

HLMC(*)-R12- () and HLMCSC-R12

Standard

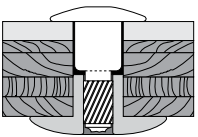

HLP30-R12- () and
HLP30-R12

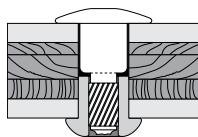

HLP30-R12- () and
HLP30-R12

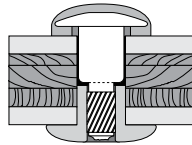

HLP30-R12- () and
HLP30-R12

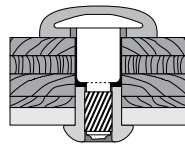

HLP30-R12- () and
HLP30-R12

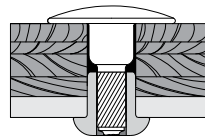

HLP30-R12- () and
HLP30-R12

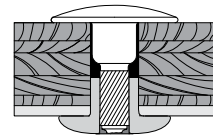

HLP30-R12- () and
HLP30-R12

Materials Legend



Aluminum, steel, etc.

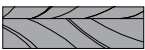

FRP or other clamp-sensitive material.



Metal-clad or other clamp-sensitive material.

Note: Only wide bearing heads to be used directly against FRP (i.e. HLP30, HLP30, and HLP30)

Hucktainer Installation Tooling

Howmet Fastening Systems offers air and hydraulic Huck® brand installation tools and nose assemblies to accommodate all fastener types, diameters, and applications. Air tools operate on 90-100 psi air pressure; the lighter weight hydraulic tools operate on pressurized hydraulic fluid supplied by an electrically powered Huck Powerig® unit. Hydraulic hose kits for Powerig units are available in lengths of 12 to 52 feet.

Hucktainer Installation Tooling						
TOOL	NOSE ASSEMBLY	WEIGHT (LBS)	SIZE (L X W X H)	STROKE (INCHES)	PULL FORCE (LBS)	TYPE
PNEUDRAULIC TOOLS						
2025	99-3464 99-3464-1	5.75	8.4" x 4.4" x 12.5"	0.675	5290	
255	99-3438	8.8	7.1" x 4.6" x 14.9"	0.625	7750	CONCENTRIC
256	99-3438	11.1	7.8" x 6.1" x 14.9"	0.88	9986	CONCENTRIC
245	99-3438	8.8		0.625	7750	ECCENTRIC
246	99-3438	11.1		0.88	9986	ECCENTRIC
HYDRAULIC TOOLS						
2480	99-3464 99-3464-1	2.2	8.6" x 1.9" x 6.5"	0.875	5700	
2580	99-3438	6.1	8.4" x 2.2" x 6.5"	0.94	10700	

Powerigs®					
MODEL	FLOW RATE	WEIGHT (LBS)	SIZE (L X W X H)	POWER	
918	2 GPM	708	44" x 25" x 30"	ELECTRICAL: 220, 440, 550 VOLTS, 3 PHASE	
940	70 IN ³ /MIN FLOW RATE	75	12.5" x 10.5" x 18"	ELECTRICAL: 115, 220 VOLTS, 1 PHASE	
913H	139 IN ³ /MIN FLOW RATE	175	24" x 21" x 27"	GASOLINE	
968	50 IN ³ /MIN FLOW RATE	93	10.5" x 16.3" x 15.7"	COMPRESSED AIR, MINIMUM 50 CPM	





**HOWMET
AEROSPACE**

Howmet Fastening Systems

Industrial Division Brands



North America

Waco Operations

PO Box 8117
8001 Imperial Drive
Waco, TX 76714-8117
Tel: +1 800-388-4825
Fax: +1 800-798-4825
hfs.sales.waco@howmet.com

Kingston Operations

1 Corporate Drive
Kingston, NY 12401
Tel: +1 800-278-4825
Fax: +1 845-334-7333
hfs.sales.kingston@howmet.com

Tracy Operations

1925 North MacArthur Drive
Tracy, CA 95376
Tel: +1 800-826-2884
Fax: +1 800-573-2645
hfs.sales.idg@howmet.com

Global

Telford Operations

Unit C, Stafford Park 7
Telford, Shropshire
England TF3 3BQ
Tel: +44 (0) 1952-290011
Fax: +44 (0) 1952-290459
thisales@howmet.com

Suzhou Operations

58 Yinsheng Road,
SIP Suzhou, Jiangsu
215126 China
Tel: +86-512-62863800-8888

Melbourne Operations

1508 Centre Road
Clayton, Victoria
Australia 3168
Tel: +613-8545-3333
Fax: +613-8545-3390
hfs.sales@howmet.com

Tokyo Operations (Japan & Korea)

1013 Hibiya U-1 Bldg.
Uchisaiwai-cho 1-1-7
Chiyoda-ku, Tokyo
100-0011 Japan
Tel: +81-3-3539-6594
Fax: +81-3-3539-6585

hfsindustrial.com

[YouTube.com/HFSIndustrial](https://www.youtube.com/HFSIndustrial)

The information contained in this publication is only for general guidance, and is not intended to create any warranty, express, implied, or statutory; all warranties are contained only in Howmet Fastening Systems' written quotations, acknowledgments, and/or purchase orders. It is recommended that the user secure specific, up-to-date data and information regarding each application and/or use of such products.