



# C50L<sup>®</sup> HuckBolt<sup>®</sup>

Huck-Engineered Lockbolts for the  
Most Challenging Applications

Vibration Resistant  
Longer Fatigue Life  
Consistent Installations

1/2"– 1-3/8"





# C50L<sup>®</sup> HuckBolt<sup>®</sup>

## Grade 5 Fasteners Certified to Meet or Exceed all ASTM A-325 Standards

For applications ranging from railcar to mining equipment manufacturing, C50L<sup>®</sup> HuckBolt<sup>®</sup> fasteners from Howmet Fastening Systems and Rings offer superior vibration resistance and overall durability. Heavy-duty applications demand tough, reliable fasteners. And extensive testing has demonstrated that C50L HuckBolt fasteners meet or exceed the performance of torqued bolts in both shear and tensile strength (with a longer fatigue life). Value is built in, too. Over the lifetime of your product, the investment you make in the quality of C50L HuckBolt fasteners will pay for itself. You won't find a stronger, more reliable fastening system, no matter what your application.



## Installation Sequence

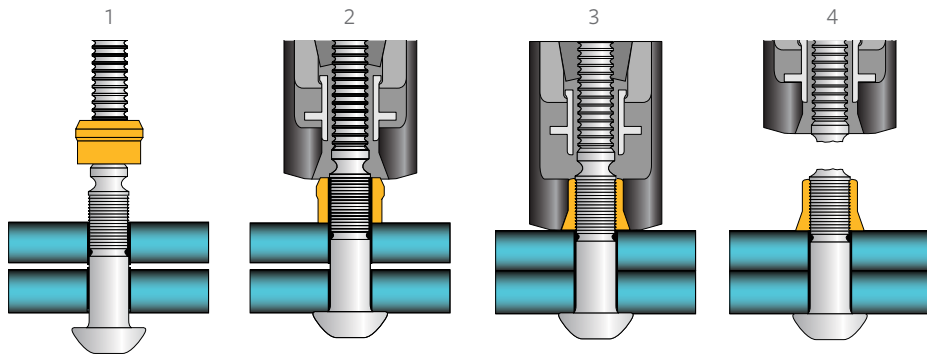

1 The pin is inserted into the prepared hole and the smooth bore collar is placed on the pin.

2 The installation tool is applied to the pintail. When the tool is activated, the jaws in the nose assembly pull on the pintail and the nose anvil pushes on the collar to remove any gap.

3 The nose anvil starts to swage the collar into the lockgrooves on the pin. Continued swaging causes the collar to lengthen and develop clamp.

4 When swaging of the collar into the lockgrooves is complete, the pintail separates from the pin which completes the installation cycle.

The C50L HuckBolt system is engineered to be installed without torquing or multiple impacts. Noise level is significantly reduced, and as a result, your installation area becomes quieter, less stressful, and more productive.

## Successful, Consistent Installations

Unlike threaded fasteners, the C50L HuckBolt delivers consistent installation results. High costs of calibrating, maintaining, and replacing tools are eliminated. And installation does not require expensive, highly experienced workers.

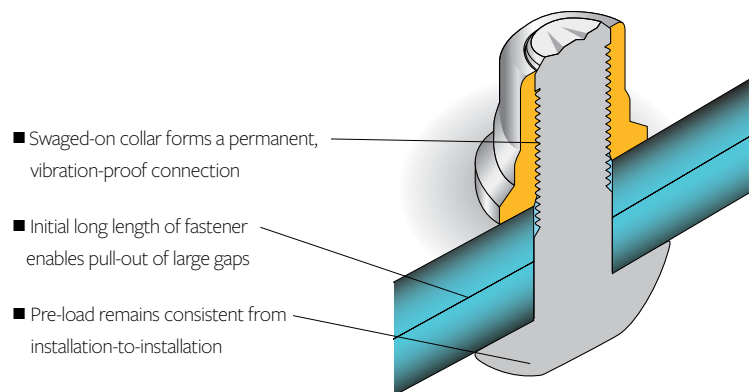

- Swaged-on collar forms a permanent, vibration-proof connection
- Initial long length of fastener enables pull-out of large gaps
- Pre-load remains consistent from installation-to-installation

# Ordering Information

Follow the form below to construct a part number for ordering C5oL pins and their respective collars. Refer to the Grip Tables (page 4) for grip numbers.

## Pins

C5oL (HEAD STYLE) - (MATERIAL) (DIAMETER) - (GRIP NUMBER) - (COATING)

Example: C5oLR-BR16-4 is a C5oL HUCKBOLT fastener, Round Head, Carbon Steel, 1/2" Diameter, Grip 4

BOLT HEAD STYLE	PREFIX	BOLT MATERIAL	CODE	DIAMETER	CODE	GRIP	FINISH	SUFFIX
ROUND	R	CARBON STEEL	BR	1/2"	16	REFER TO GRIP TABLES ON PAGE 5	ZINC PLATE, CLEAR CHROMATE .0003"	G
TRUSS	T			5/8"	20		ZINC PLATE, CLEAR CHROMATE .0004"	GA
STAINLESS CAP	C	ALUMINUM 2024 AND 6061 SPECIAL ORDER ONLY		3/4"	24		GEOMET - 1 COAT	NP
LARGE TRUSS	30			7/8"	28		GEOMET - 2 COAT	D1
90° FLUSH	90			1"	32		GEOMET - 3 COAT	DL
60° FLUSH	60	STAINLESS STEEL AVAILABLE ON REQUEST		1-1/8"	36		OIL FINISH	NO SUFFIX
				1-3/8"	44			

## Collars

(COLLAR STYLE) - (MATERIAL) (DIAMETER) (COATING) (OPTIONS)

Example: LC-2R16G is a Standard Collar, Low Carbon Steel, 1/2" Diameter, Zinc Finish

COLLAR STYLE	PREFIX	MATERIAL	CODE	DIAMETER	CODE	COATING	CODE	OPTIONS	SUFFIX
STANDARD	LC-	LOW CARBON STEEL	2R	1/2"	16	ZINC	G	TAB-LOK	L
FLANGED	3LC-			5/8"	20	ADDITIONAL COATING OPTIONS AVAILABLE			
LOW PROFILE	8LC-	ALUMINUM SPECIAL ORDER ONLY		3/4"	24				
LOW PROFILE (44)	AC-R44			7/8"	28				
				1"	32				
				1-1/8"	36				
				1-3/8"	44				

**Tab-Lok™**

The Tab-Lok feature makes sure the collar stays on the pin, before installation, in overhead and down slanted pin placements.

To order Tab-Lok collars refer to adjacent charts.



# Data and Dimensions

## Head Style Options

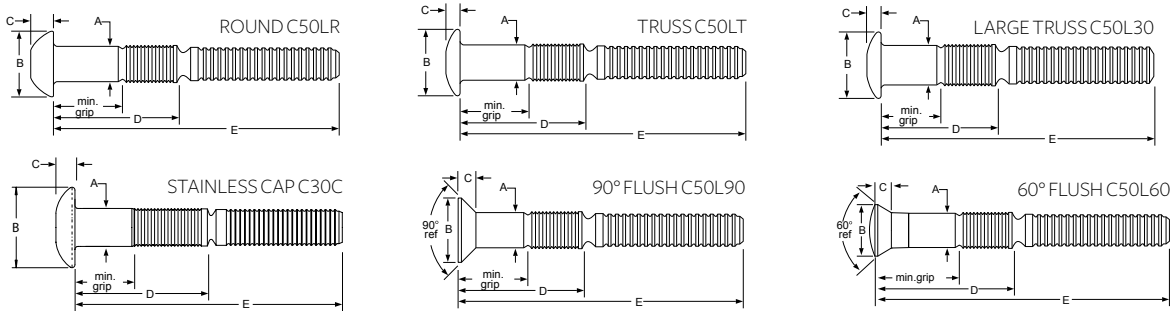

## Fastener Dimensions

		ROUND HEAD			TRUSS HEAD C50LT		C50L30		90° FLUSH HEAD		STAINLESS STEEL CAPPED HEAD		C50L60	
DIAMETER	CODE	A	B	C	B	C	B	C	B	C	B	C	B	C
1/2"	16	.493-.515	.870-940	.310-.320	.875-.938	.215-.260	1.027-1.09	.251-.281	.870-940	.225-.239	—	v	—	—
5/8"	20	.617-.642	1.086-1.196	.367-.432	1.086-1.196	.267-.432	1.288-1.375	.298-.328	1.093-1.183	.284-.300	1.33-1.44	.33-.39	—	—
3/4"	24	.740-.770	1.328-1.438	.455-.530	1.328-1.438	.323-.398	—	—	1.312-1.417	.350-.380	—	c	1.101-1.125	.337-.357
7/8"	28	.865-.900	1.540-1.660	.530-.580	1.540-1.660	.395-.445	—	—	1.531-1.655	.396-.430	—	—	1.298-1.338	.393-.413
1"	32	1.025-.990	1.750-2.000	.590-.650	—	—	—	—	—	—	—	—	1.478-1.522	.454-.474
1-1/8"	36	1.095-1.125	2.000-2.125	.656-.720	—	—	—	—	—	—	—	—	1.661-1.715	.506-.526
1-3/8"	44	1.400-1.350	2.470-2.590	.815-.880	—	—	—	—	2.448-2.572	.648-.703	—	—	—	—

## Grip Tables\*

GRIP	GRIP RANGE	1/2" (16)		5/8" (20)		3/4" (24)		7/8" (28)		1" (32)		1-1/8" (36)		1-3/8" (44)
		D	E	D	E	D	E	D	E	D	E	D	E	
4	.250-.500	1.213	3.172	1.433	3.656	1.518	4.156	—	—	—	—	—	—	UP TO 34.25" CALL FOR DATA
8	.500-.750	1.463	3.422	1.683	3.906	1.768	4.406	1.921	4.688	2.073	5.375	—	—	
12	.750-1.000	1.713	3.672	1.933	4.156	2.018	4.656	2.171	4.938	2.323	5.625	—	—	
16	1.000-1.250	1.963	3.922	2.183	4.406	2.268	4.906	2.421	5.188	2.573	5.875	—	—	
20	1.250-1.500	2.213	4.172	2.433	4.656	2.518	5.156	2.671	5.438	2.823	6.125	—	—	
24	1.500-1.750	2.463	4.422	2.683	4.906	2.768	5.406	2.921	5.688	3.073	6.375	—	—	
28	1.750-2.000	2.713	4.672	2.933	5.156	3.018	5.656	3.171	5.938	3.323	6.625	—	—	
32	2.000-2.250	2.963	4.922	3.183	5.406	3.268	5.906	3.421	6.188	3.573	6.875	—	—	
36	2.250-2.500	3.213	5.172	3.433	5.656	3.518	6.156	3.671	6.438	3.823	7.125	—	—	
40	2.500-2.750	3.463	5.422	3.683	5.906	3.768	6.406	3.921	6.688	4.073	7.375	—	—	
44	2.750-3.000	3.713	5.672	3.933	6.156	4.018	6.656	4.171	6.938	4.323	7.625	—	—	
48	3.000-3.250	3.963	5.922	4.183	6.406	4.268	6.906	4.421	7.188	4.573	7.875	—	—	
52	3.250-3.500	4.213	6.172	4.433	6.656	4.518	7.156	4.671	7.438	4.823	8.125	—	—	
56	3.500-3.750	4.463	6.422	4.683	6.906	4.768	7.406	4.921	7.688	5.073	8.375	5.250	8.563	
60	3.750-4.000	4.713	6.672	4.933	7.156	5.018	7.656	5.171	7.938	5.323	8.625	5.500	8.813	
64	4.000-4.250	4.963	6.922	5.183	7.406	5.268	7.906	5.421	8.188	5.573	8.875	5.750	9.063	
68	4.250-4.500	5.213	7.172	5.433	7.656	5.518	8.156	5.671	8.438	5.823	9.125	6.000	9.313	
72	4.500-4.750	5.463	7.422	5.683	7.906	5.768	8.406	5.921	8.688	6.073	9.375	6.250	9.563	
76	4.750-5.000	5.713	7.672	5.933	8.156	6.018	8.656	—	—	6.323	9.625	6.500	9.813	
80	5.000-5.250	5.963	7.922	—	—	—	—	—	—	6.573	9.875	6.750	1.063	
84	5.250-5.500	—	—	—	—	—	—	—	—	6.823	1.125	7.000	1.313	
88	5.500-5.750	—	—	—	—	—	—	—	—	7.073	1.375	7.250	1.563	
92	5.750-6.000	—	—	—	—	—	—	—	—	7.323	1.625	7.500	1.813	

\*All grips are calculated using a LC collar

### Collar Dimensions

STYLE	DIAMETER	F	G	H	J	K	L
LC	1/2"	.515-.540	.765-.800	.610-.645	—	—	—
	5/8"	.650-.665	.970-.985	.845-.875	—	—	—
	3/4"	.776-.790	1.165-1.180	.930-.960	—	—	—
	7/8"	.896-.920	1.355-1.375	1.083-1.120	—	—	—
	1"	1.030-1.050	1.550-1.575	1.235-1.280	—	—	—
	1-1/8"	1.150-1.180	1.740-1.770	1.390-1.440	—	—	—
3LC	1/2"	.510-.535	.793-.807	.726-.756	.094-.156	.969-1.031	—
	5/8"	.650-.665	.980-.996	.929-.959	.125-.187	1.218-1.281	—
	3/4"	.776-.790	1.170-1.195	1.109-1.155	.156-.218	1.480-1.525	—
	7/8"	.896-.920	1.360-1.370	1.293-1.339	.187-.250	1.570-1.615	—
	1"	1.030-1.050	1.550-1.565	1.485-1.515	.218-.281	1.843-1.906	—
	1-1/8"	1.160-1.175	1.750-1.760	1.675-1.715	.273-.289	2.105-2.145	—
8LC	1/2"	.515-.535	.780-.800	.470-.500	—	—	.140-.145
	5/8"	.640-.665	.972-.982	.670-.700	—	—	.175
	3/4"	.775-.790	1.165-1.180	.715-.745	—	—	.215
	7/8"	.910-.930	1.360-1.375	.833-.863	—	—	.250-.257
	1"	1.030-1.050	1.552-1.568	.950-.980	—	—	.285-.300
AC-R44	1-3/8"	1.409-1.419	2.147-2.157	1.738-1.762	—	—	—

STANDARD-LC

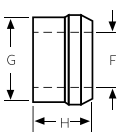

FLANGED-3LC<sup>1</sup>

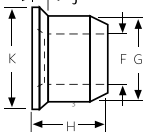

LOW PROFILE-8LC<sup>2</sup>/LC-2R

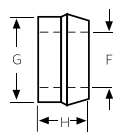

AC-R44

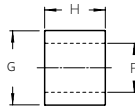

<sup>1</sup> When using a 3LC collar the minimum grip is equal to the Min grip using a LC collar - "nominal J", Maximum grip is equal to the Max grip using the LC collar - "nominal J" ("J" represents the flange thickness of the 3LC)

<sup>2</sup> When using an 8LC collar - Min grip is equal to LC Min Grip (See Table), Max Grip is equal to Min grip + grip range + "L" ("L" is the difference in height between the 8LC and LC collars.)

# Data and Dimensions

Installed Fastener Values									
DIAMETER	CARBON STEEL PINS LC-2R OR 3LC-2R COLLARS (MIN LBF)			2024C ALUMINUM PINS LC-F OR 3LC-F COLLARS (MIN LBF)			6061F ALUMINUM PINS LC-I OR 3LC-I COLLARS (MIN LBF)		
	SHEAR	CLAMP	TENSILE	SHEAR	CLAMP	TENSILE	SHEAR	CLAMP	TENSILE
1/2"	14400	12050	17050	7300	5900	7850	5300	4400	4900
5/8"	22500	19200	27100	11400	9200	12300	8300	6900	7670
3/4"	32400	28400	40100	16400	13300	17700	11900	9950	11040
7/8"	43400	39250	55450	SPECIAL ORDER ONLY					
1"	56500	51500	72700						
1-1/8"	69500	58450	82950	—	—	—	—	—	—
1-3/8"	100000	85000	129500	—	—	—	—	—	—

Inspection Data								
DIAMETER	PIN PART NO.	LC COLLAR	3LC COLLAR	8LC COLLAR	A MAX	B MAX	C MIN	D MAX
1/2"	C50L(-)( )16	LC-2R16G	3LC-2R16G	8LC-2R16G	.063	.375	.406	.733
5/8"	C50L(-)( )20	LC-2R20G	3LC-2R20G	8LC-2R20G	.063	.375	.625	.916
3/4"	C50L(-)( )24	LC-2R24G	3LC-2R24G	8LC-2R24G	.063	.375	.656	1.110
7/8"	C50L(-)( )28	LC-2R28G	3LC-2R28G	8LC-2R28G	.063	.375	.750	1.282
1"	C50L(-)( )32	LC-2R32G	3LC-2R32G	8LC-2R32G	.063	.375	.875	1.465
1-1/8"	C50LR-BR36	LC-2R36G	—	8LC-2R36G	.063	.625	.906	1.646
1-3/8"	C50LR-BR44	AC-R44U	—	—	.188	.688	1.250	2.020

Hole Data	
DIAMETER	MAX HOLE
1/2"	.563
5/8"	.688
3/4"	.813
7/8"	.938
1"	1.063
1-1/8"	1.188
1-3/8"	1.500

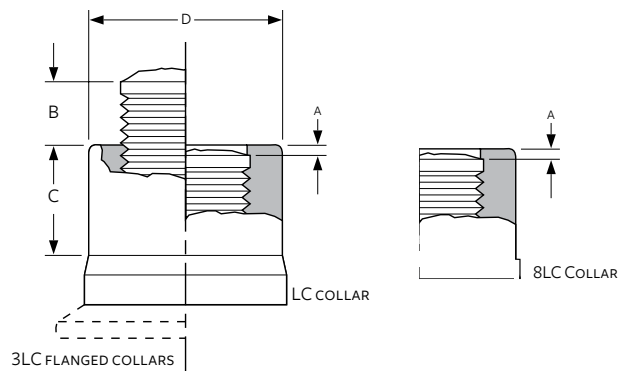

# Installation Tooling

## Hydraulic Tools & Nose Assemblies

NOSE ASSEMBLY	SIZE	TOOL MODEL						
		2620	2620PT	2624	3585	2630	507	12142
	1/2"	99-5000	99-5002	99-5021	99-5021			
	5/8"			99-5008	99-5008			
	3/4"				99-5010			
	7/8"					99-5014		
	1"						99-5016	
	1-1/8"						99-5019	
	1-3/8"							INTEGRAL



## Tooling Weight and Dimensions

MODEL	WEIGHT	LENGTH	HEIGHT	WIDTH
2620/2620-PT*	1.4/11.0 LBS.	6.60"/1.10"	7.0"	2.82"
2624	13.9 LBS.	7.37"	7.73"	3.48"
3585	18.5 LBS.	7.84"	1.36"	4.02"
2630	22.3 LBS.	7.90"	8.65"	4.44"
507	43.4 LBS.	15.50"	6.00"	5.40"
12142	6.0 LBS.	11.76"	6.56"	6.56"

*For limited clearance installation tools contact manufacturer.*

## Huck Powerig® Hydraulic Units

MODEL 918/918-5	MODEL 940	MODEL 913H (NOT SHOWN)	MODEL 968 (NOT SHOWN)
HIGH-PRODUCTION APPLICATIONS	PORTABLE; PRODUCTION AND REPAIR	PORTABLE; PRODUCTION AND REPAIR	PORTABLE; PRODUCTION AND REPAIR
918 POWERS 2 TOOLS (2 GPM/TOOL) 918-5 POWERS 3 TOOLS (1.3 GPM/TOOL)	70 IN. <sup>3</sup> /MIN. FLOW RATE (.3 GPM)	139 IN. <sup>3</sup> /MIN. FLOW RATE (.6 GPM)	70 IN. <sup>3</sup> /MIN. FLOW RATE (.3 GPM)
ELECTRICALLY POWERED; 220, 440, OR 550 VOLTS, 3 PHASE	ELECTRICALLY POWERED; 115 OR 220 VOLTS, SINGLE PHASE	GASOLINE POWERED	AIR POWERED; 50 CFM (.024 M <sup>3</sup> /s)
WEIGHS 585/601 LBS. WITHOUT HYDRAULIC FLUID	WEIGHS 66 LBS. WITHOUT HYDRAULIC FLUID	WEIGHS 122 LBS. WITHOUT HYDRAULIC FLUID	WEIGHS 75 LBS. WITHOUT HYDRAULIC FLUID
44"L x 25"W x 30"H	13.9"L x 16.1"W x 18.5"H	24"L x 21"W x 27"H	1.45'L x 16.33"W x 15.68"H



Powerig Model 918/918-5



Powerig Model 940



**HOWMET  
AEROSPACE**

# Howmet Fastening Systems

## Industrial Division Brands



Huck, Marson, Recoil, Keysert, Camloc, Simmonds and Snep are trademarks of Howmet Aerospace Inc. and/or its subsidiaries.

### North America

#### Waco Operations

PO Box 8117  
8001 Imperial Drive  
Waco, TX 76714-8117  
Tel: +1 800-388-4825  
Fax: +1 800-798-4825  
hfs.sales.waco@howmet.com

#### Kingston Operations

1 Corporate Drive  
Kingston, NY 12401  
Tel: +1 800-278-4825  
Fax: +1 845-334-7333  
hfs.sales.kingston@howmet.com

#### Tracy Operations

1925 North MacArthur Drive  
Tracy, CA 95376  
Tel: +1 800-826-2884  
Fax: +1 800-573-2645  
hfs.sales.idg@howmet.com

### Global

#### Telford Operations

Unit C, Stafford Park 7  
Telford, Shropshire  
England TF3 3BQ  
Tel: +44 (0) 1952-290011  
Fax: +44 (0) 1952-290459  
thisales@howmet.com

#### Suzhou Operations

58 Yinsheng Road,  
SIP Suzhou, Jiangsu  
215126 China  
Tel: +86-512-62863800-8888

#### Melbourne Operations

1508 Centre Road  
Clayton, Victoria  
Australia 3168  
Tel: +613-8545-3333  
Fax: +613-8545-3390  
hfs.sales@howmet.com

#### Tokyo Operations (Japan & Korea)

1013 Hibiya U-1 Bldg.  
Uchisaiwai-cho 1-1-7  
Chiyoda-ku, Tokyo  
100-0011 Japan  
Tel: +81-3-3539-6594  
Fax: +81-3-3539-6585

[hfsindustrial.com](http://hfsindustrial.com)

[YouTube.com/HFSIndustrial](https://www.youtube.com/HFSIndustrial)

The information contained in this publication is only for general guidance, and is not intended to create any warranty, express, implied, or statutory; all warranties are contained only in Howmet Fastening Systems' written quotations, acknowledgments, and/or purchase orders. It is recommended that the user secure specific, up-to-date data and information regarding each application and/or use of such products.