



HuckLok[®] Blind Rivets

Double-Locking, Wide-Grip Fasteners for
Superior Strength in a Broad Variety
of Applications





HuckLok®

A Structural Bulbing Fastener Ideal for Joining a Broad Range of Materials with Variation of Grip Thicknesses.

Featuring a wide grip range and unique double-locking action, the HuckLok® structural blind rivet combines high shear strength and high pull-up force. Its double-locking action consistently secures the assembly from both sides, resulting in maximum hold and joint integrity. Its large, blind-side footprint prevents pull-through, even when joining a wide range of materials with varying grip thicknesses.

In addition, HuckLok's® positive mechanical core pin retention design ensures structural integrity and long joint life. Its breakaway ring design lets the shear ring settle into the appropriate catch groove, keeping pressure on the blindside and securing a consistent clamp throughout the entire wide grip range.

Designed to add efficiency to a wide range of joining applications, HuckLok blind rivets are easy to install in seconds. A quick visual review is all that is necessary to confirm the accuracy of the installation, since the installed HuckLok's core pin being flush on the head of the sleeve is proof of the success of the process.

Available Sizes:

3/16", 1/4"

Materials:

Steel

Headstyles:

Protruding, Truss, 100° Oval Flush



Installation Sequence

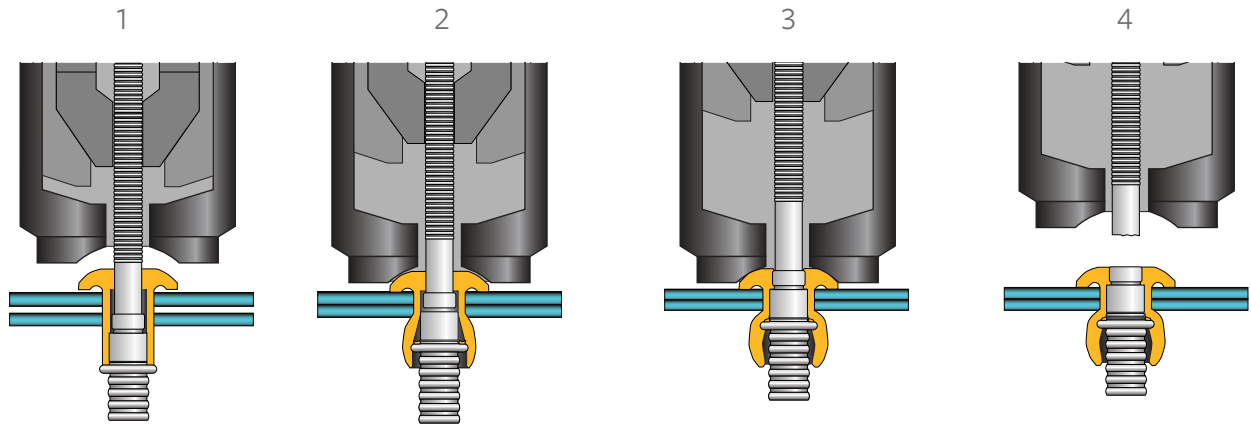

1
Insert the fastener into the hole and slip the installation tool over the pintail.

2
Press the trigger to initiate pulling action. As the tool pulls on the pintail, the shear ring feature on the pin pulls inside the sleeve fully expanding the diameter and drawing the work pieces together.

3
Continued pulling on the pintail expands the sleeve to maximum allowable diameter. As the shear ring reaches the backside of the work piece it breaks and catches on the tapered annular grooves, keeping high pressure on the blind side of the work pieces as the pin continues to draw down inside the sleeve.

4
A solid circle lock between the pin and sleeve is formed just prior to the pin breaking flush with the sleeve head, completing the installation.

Secure, Fast Installation

Breaking flush throughout its grip range, the HuckLok blind rivet lets the worker verify installation accuracy at a glance and eliminates costly cosmetic finishing

Undercut fillet allows seating in burred holes

Solid pin provides exceptionally high strength in the shear plane

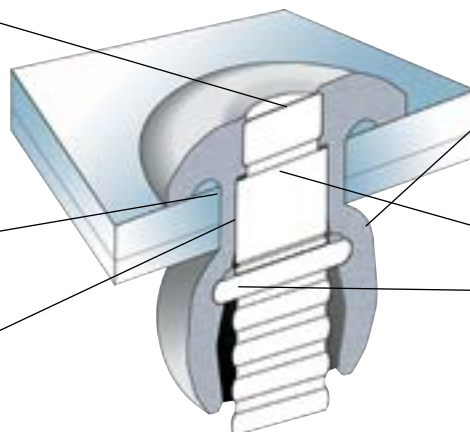

The HuckLok's wide footprint provides a broad blind-side bearing surface that resists pull-through

Lock groove on pin engages shoulder on rivet head, while the support ring "double locks" the pin within the bulb

Data and Dimensions

Head Style Options



Fastener Dimensions

DIAM.	PART NUMBER		GRIP RANGE (IN)	GRIP RANGE (MM)	HOLE SIZE	A NOM	B MAX		C MAX	D MAX	E MAX	F MIN
	PROTRUDING	TRUSS					PROTRUDING	TRUSS				
6 (3/16")	HKLP-R6-5	-	.062 - .312	1.6 - 7.9	.191 - .201	0.187	0.395	-	0.101	0.458	0.8555	0.988
	HKLP-R6-7	-	.187 - .437	4.7 - 11.1	.191 - .201	0.187	0.395	-	0.101	0.583	0.9805	0.978
8 (1/4")	HKLP-R8-6	HKLT-R8-6	.100 - .375	2.5 - 9.5	.261 - .272	0.253	0.530	0.592	0.122	0.560	1.019	1.082
	HKLP-R8-6X	HKLT-R8-6X	.080 - .375	2.0 - 9.5	.261 - .272	0.253	0.530	0.592	0.122	0.560	1.019	1.082
	HKLP-R8-X6	-	.160 - .375	4.6 - 9.5	.261 - .272	0.253	0.530	-	0.122	0.560	1.019	1.102
	HKLP-R8-7	HKLT-R8-7	.187 - .437	4.7 - 11.1	.261 - .272	0.253	0.530	0.592	0.122	0.622	1.081	1.065
	HKLP-R8-10	HKLT-R8-10	.375 - .625	9.5 - 15.9	.261 - .272	0.253	0.530	0.592	0.122	0.810	1.269	1.065
	HKLP-R8-12	HKLT-R8-12	.500 - .750	12.7 - 19.1	.261 - .272	0.253	0.530	0.592	0.122	0.934	1.393	1.066
	HKLP-R8-14	HKLT-R8-14	.625 - .875	15.9 - 22.2	.261 - .272	0.253	0.530	0.592	0.122	1.060	1.519	1.065
	HKLP-R8-18	HKLT-R8-18	.875 - 1.125	22.2 - 28.6	.261 - .272	0.253	0.530	0.592	0.122	1.310	1.769	1.065
HKLP-R8-20	HKLT-R8-20	1.000 - 1.250	25.4 - 31.8	.261 - .272	0.253	0.530	0.592	0.122	1.435	1.894	1.065	

Installed Values - Ibf (Minimum)

DIAM.	PART NUMBER		SHEAR		TENSILE		RETENTION	
			MIN	TYP	MIN	TYP	MIN	TYP
6 (3/16")	HKLP	ALL GRIPS	1900	2500	1000	1300	150	450
8 (1/4")	HKLP/HKLT	ALL GRIPS	3500	3800	1900	2200	300	650



Lock groove on pin engages shoulder on rivet head, while the support ring "double locks" the pin within the bulb.

Materials and Finishes

MATERIAL	SLEEVE	PIN	SLEEVE FINISH	PIN FINISH
STEEL	LOW CARBON STEEL	MEDIUM CARBON STEEL	ZINC PLATE WITH CLEAR GOLD DYE OPTIONAL	ZINC PLATE WITH CLEAR GOLD DYE OPTIONAL

Ordering Information

HKL(HEAD STYLE) - (MATERIAL) (DIAMETER) — (GRIP NUMBER)

Example: HKLP-R6-5 is a Protruding Head HuckLok, Steel, 3/16" Diameter, 5/16" Grip

HEAD STYLE	PREFIX
PROTRUDING HEAD	P
TRUSS HEAD	T

MATERIAL	CODE
STEEL	R
-	-

DIAMETER	CODE
3/16"	6
1/4"	8



Installation Tooling

Tooling Weight and Dimensions					
MODEL	TYPE	WEIGHT	LENGTH	HEIGHT	WIDTH
BV4500-118	BATTERY	5 LBS	9.06"	9.42"	3.15"
256	PNEUDRAULIC	11.1 LBS	7.9"	14.9"	6.3"
2024*	PNEUDRAULIC	5.75 LBS	8.9"	12.6"	4.4"
2480	HYDRAULIC	2.2 LBS	8.2"	6.6"	1.9"
2581	HYDRAULIC	5.5 LBS	8.4"	7.1"	2.1"

Installation Tools						
NOSE ASSEMBLY	SIZE	BATTERY TOOLS	PNEUDRAULIC TOOLS			HYDRAULIC TOOLING
		TOOL MODEL				
		BV4500-118	256	2024*	2480	2581
	3/16"	99-3303	99-3327	99-3303	99-3303	99-3327
3/16" & 1/4"	99-3487**	-	99-3487**	-	-	
1/4"	99-3305	99-3328	99-3305	99-3305	99-3328	

* Recommended

** Not recommended for high volume production



Huck Pneudraulic Tooling



256

Designed for quick installation of fasteners, the 256 tool features optimum stroke for one-cycle fastener installation, and minimal moving parts. Comes with standard inline and offset nose assemblies, ranging from 4mm to 10mm.



2024

Designed for production volume fastening, the 2024 offers a number of outstanding features, including an ergonomically designed handle, plated piston rods and an efficient in-line piston. An extended piston version (2024L) is available and an optional vacuum assist pintail collection system (2024V) can be added.

Huck Hydraulic Tooling



2480

The Model 2480 is a very lightweight tool which provides for the high-speed installation of a wide range of HuckBolt and Huck blind bolt fasteners. The tool has only one moving part, resulting in outstanding reliability and minimal maintenance. The tight centerline-to-edge measurement of the Model 2480 and its light weight (2.21 pounds) allow for its use in limited clearance areas.



2581

The Model 2581 is a lightweight tool (only 6.58 pounds) designed for use in a wide range of high-speed production applications. With only one moving part, the tool provides for increased reliability and requires minimal maintenance. An offset piston design allows the Model 2580 to easily fit in limited clearance applications.

Huck Battery Tooling



BV4500-118

The Huck Range Force battery tool has an electronically adjustable pull force and long stroke to enable installation of structural and non-structural rivets and up to 1/4" two-piece HuckBolt fasteners. Along with an 18V 5Ah battery, the Huck Range Force by Makita is a force to be reckoned with in portability, reliability and versatility.



**HOWMET
AEROSPACE**

Howmet Fastening Systems

Industrial Division Brands



Huck, Marson, Recoil, Keysert, Camloc, Simmonds and Snep are trademarks of Howmet Aerospace Inc. and/or its subsidiaries.

North America

Waco Operations

PO Box 8117
8001 Imperial Drive
Waco, TX 76714-8117
Tel: +1 800-388-4825
Fax: +1 800-798-4825
hfs.sales.waco@howmet.com

Kingston Operations

1 Corporate Drive
Kingston, NY 12401
Tel: +1 800-278-4825
Fax: +1 845-334-7333
hfs.sales.kingston@howmet.com

Tracy Operations

1925 North MacArthur Drive
Tracy, CA 95376
Tel: +1 800-826-2884
Fax: +1 800-573-2645
hfs.sales.idg@howmet.com

Global

Telford Operations

Unit C, Stafford Park 7
Telford, Shropshire
England TF3 3BQ
Tel: +44 (0) 1952-290011
Fax: +44 (0) 1952-290459
thisales@howmet.com

Suzhou Operations

58 Yinsheng Road,
SIP Suzhou, Jiangsu
215126 China
Tel: +86-512-62863800-8888

Melbourne Operations

1508 Centre Road
Clayton, Victoria
Australia 3168
Tel: +613-8545-3333
Fax: +613-8545-3390
hfs.sales@howmet.com

Tokyo Operations (Japan & Korea)

1013 Hibiya U-1 Bldg.
Uchisaiwai-cho 1-1-7
Chiyoda-ku, Tokyo
100-0011 Japan
Tel: +81-3-3539-6594
Fax: +81-3-3539-6585

hfsindustrial.com

[YouTube.com/HFSIndustrial](https://www.youtube.com/HFSIndustrial)

The information contained in this publication is only for general guidance, and is not intended to create any warranty, express, implied, or statutory; all warranties are contained only in Howmet Fastening Systems' written quotations, acknowledgments, and/or purchase orders. It is recommended that the user secure specific, up-to-date data and information regarding each application and/or use of such products.