

HUCK**HUCK MANUFACTURING COMPANY****ENGINEERING
STANDARD**

Aerospace Fasteners
Division
900 Watsoncenter Road
© Carson, CA 90745

Industrial Fasteners
Division
P.O. Box 8117
Waco, TX 76710

Installation Equipment
Division
85 Grand Street
Kingston, NY 12401

Canadian Headquarters
326 Humber College Blvd.
Rexdale, Ontario, M9W 5P4
Canada

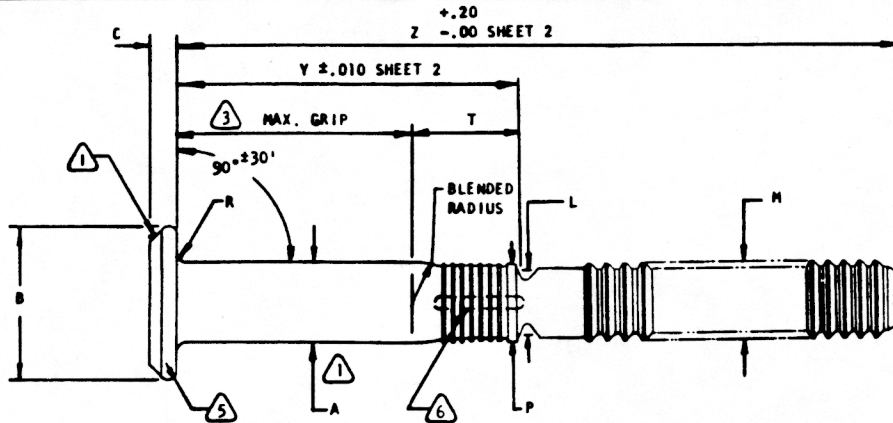

GP PIN FAMILY NUMBER	NOM. SIZE	A SHANK DIA. (BARE)		A SHANK DIA. (PLATED)		B HEAD DIA.		C HEAD HEIGHT		L DIA.	M DIA.	P DIA.	R RADIUS		S	T
		MAX.	MIN.	MAX.	MIN.	MAX.	MIN.	MAX.	MIN.	REF.	MAX.	MAX.	MAX.	MIN.	△ 2	REF.
GPL7TP-EU06-()	.190	.1895	.1890	.1895	.1885	.377	.357	.074	.064	.164	.184	.184	.025	.015	.0045	.264
GPL7TP-EU08-()	.250	.2495	.2490	.2495	.2485	.440	.415	.090	.080	.224	.244	.244	.025	.015	.0045	.312
GPL7TP-EU10-()	.312	.3120	.3115	.3120	.3110	.502	.472	.112	.102	.268	.306	.306	.030	.020	.0045	.402
GPL7TP-EU12-()	.375	.3745	.3740	.3745	.3735	.565	.530	.140	.130	.339	.368	.370	.030	.020	.0060	.472

- 1 CONCENTRICITY: CONICAL SURFACE OF PROTRUDING HEAD TO "A" DIAMETER TO BE WITHIN 5% OF "A" DIAMETER TIR.
- 2 SHANK STRAIGHTNESS: WITHIN "S" VALUES TIR PER INCH OF SHANK LENGTH.
- 3 GRIP LENGTH NUMBER: TO DETERMINE THE GRIP LENGTH NUMBER DIVIDE THE DIMENSIONAL THICKNESS OF PARTS BEING JOINED BY .0625 INCH. GRIP LENGTH: TO DETERMINE THE GRIP LENGTH, MULTIPLY THE GRIP LENGTH NUMBER BY .0625 INCH. THE GRIP LENGTH IS MEASURED FROM THE UNDERSIDE OF THE HEAD TO THE END OF THE FULL CYLINDRICAL PORTION OF THE SHANK. (SEE SHEET 2).
- 4 SEE CODING UNDER USAGE AND APPLICATION FOR COMPLETE STANDARD NUMBER.
- 5 PERMISSIBLE NATURAL FLOW OF MATERIAL.

MATERIAL: A286 CRES (AISI 660) PER AMS 5737.

HEAT TREATMENT: SOLUTION TREATED AND AGED. MINIMUM SHEAR STRENGTH: 95 KSI.

FINISH: PASSIVATE PER QQ-P-35 (NO SUFFIX) OR CADMIUM PLATE PER QQ-P-416 TYPE II CLASS 2 (SUFFIX "C" ONLY).

LUBRICATION: CHLORINE FREE CETYL ALCOHOL (NO SUFFIX). ALSO AVAILABLE WITHOUT LUBE. ADD SUFFIX "B" TO PART NUMBER.

SURFACE TEXTURE: Ra MAX. PER ANSI B46.1: BEARING SURFACE, HEAD TO SHANK RADIUS, AND SHANK & LEAD-IN RADIUS -.32; OTHER SURFACES -.125.

HEAD MARKING: PIN HEAD SHALL BE MARKED WITH HUCK'S BASIC SYMBOL, BASIC NUMBER AND MATERIAL DESIGNATOR, DEPRESSED .010 MAX. SEALANT ESCAPE GROOVE: PIN HEAD SHALL BE MARKED WITH HUCK'S BASIC SYMBOL, BASIC NUMBER, MATERIAL DESIGNATOR, & DOT, DEPRESSED .010 MAX. ARRANGEMENT OPTIONAL. EXAMPLE:

EXAMPLE:



4 USAGE AND APPLICATION INFORMATION

CODING: THE FIRST SET OF LETTERS DESIGNATE THE FAMILY OF GP PINS FOR SHEAR OR TENSION APPLICATIONS (GPL). THE SECOND SET OF LETTERS & NUMBERS (7TP) DESIGNATE HEAD SIZE, STYLE AND LOAD APPLICATION. THE NEXT LETTER "EU", IS THE MATERIAL DESIGNATOR FOR A286 CRES, MIN. SHEAR STRENGTH: 95 KSI. THE NUMBERS FOLLOWING THE MATERIAL DESIGNATOR DESIGNATES THE NOMINAL PIN SHANK DIAMETER IN .0312 INCH INCREMENTS. THE FINAL NUMBER(S) DESIGNATES THE GRIP LENGTH NUMBER OR THE NOMINAL PIN SHANK LENGTH IN .0625 INCH INCREMENTS.

B — BARE-NO LUBRICATION (WHEN SPECIFIED ONLY).

EXAMPLE: (H)GPL7TP-EU08-06()



- C — CADMIUM PLATE- LUBE OR "CB" CADMIUM PLATE-BARE-NO LUBRICATION (WHEN SPECIFIED ONLY).
- .375 INCH GRIP LENGTH.
- .250 INCH SHANK DIAMETER.
- A286 CRES.
- LARGE PROTRUDING HEAD, FOR TENSION APPLICATIONS.
- FAMILY OF GP PINS FOR AEROSPACE APPLICATION.
- THE ABOVE IS ALSO AVAILABLE WITH SEALANT ESCAPE GROOVE.
- ADD PREFIX "H" TO PART NUMBER. EXAMPLE: HGPL7TP-EU08-06.

DIMENSIONS IN INCHES.

INSTALLATION EQUIPMENT: SEE SELECTION CHARTS, FORM 461.

©1985, HUCK MANUFACTURING COMPANY, ALL RIGHTS RESERVED.

U.S. Patent Nos. RE30445 and 4,221,152.

ISSUED 11-16-84

REVISED 7-22-85

SHEET 1 OF 2

**GROOVE PROPORTIONED (GP) PIN,
SWAGE LOCKING, STANDARD DIAMETER - PULL-TYPE
TENSION, PROTRUDING HEAD,
A286 CRES. (95 KSI SHEAR)**

GPL7TP-EU

PAGE NO. SK 12348

THIS DRAWING, THE STRUCTURAL DESIGN DISCLOSED THEREIN, AND THE TECHNICAL DATA AND ENGINEERING SERVICE REPRESENTED THEREBY ARE THE EXCLUSIVE PROPERTY OF THE HUCK MANUFACTURING COMPANY.

REVISION 4-3-85 UPDATED. REVISION 7-22-85 UPDATED. PATENT NOS.

HUCK**HUCK MANUFACTURING COMPANY****ENGINEERING
STANDARD**

A Subsidiary of Federal-Mogul Corporation

Aerospace Fasteners
Division
900 Watsoncenter Road
Carson, CA 90745Industrial Fasteners
Division
P.O. Box 8117
Waco, TX 76710Installation Equipment
Division
85 Grand Street
Kingston, NY 12401Canadian Headquarters
326 Humber College Blvd.
Rexdale, Ontario, M9W 5P4
Canada

GRIP NUMBER TABULATION

GRIP DASH NO.	MINIMUM PERMI- SIBLE GRIP OVERLAP	DESIGN GRIP RANGE		MAXIMUM PERMI- SIBLE GRIP OVERLAP	.190		.250		.312		.375		GRIP DASH NO.
		MIN.	MAX.		Y	Z	Y	Z	Y	Z	Y	Z	
02	.047	.063	.125	.141	.389	1.14	.437	1.28					02
03	.109	.126	.188	.203	.452	1.20	.500	1.34	.590	1.55			03
04	.172	.189	.250	.266	.514	1.26	.562	1.40	.652	1.61	.722	1.84	04
05	.234	.251	.312	.328	.576	1.32	.624	1.47	.714	1.67	.784	1.90	05
06	.297	.313	.375	.391	.639	1.39	.687	1.53	.777	1.74	.847	1.96	06
07	.359	.376	.438	.453	.702	1.45	.750	1.59	.840	1.80	.910	2.03	07
08	.422	.439	.500	.516	.764	1.51	.812	1.65	.902	1.86	.972	2.09	08
09	.484	.501	.562	.578	.826	1.57	.874	1.72	.964	1.92	1.034	2.15	09
10	.547	.563	.625	.641	.889	1.64	.937	1.78	1.027	1.99	1.097	2.21	10
11	.609	.626	.688	.703	.952	1.70	1.000	1.84	1.090	2.05	1.160	2.28	11
12	.672	.689	.750	.766	1.014	1.76	1.062	1.90	1.152	2.11	1.222	2.34	12
13	.734	.751	.812	.828	1.076	1.82	1.124	1.97	1.214	2.17	1.284	2.40	13
14	.797	.813	.875	.891	1.139	1.89	1.187	2.03	1.277	2.24	1.347	2.47	14
15	.859	.876	.938	.953	1.202	1.95	1.250	2.09	1.340	2.30	1.410	2.53	15
16	.922	.939	1.000	1.016	1.264	2.01	1.312	2.15	1.402	2.36	1.472	2.59	16
17	.984	1.001	1.062	1.078	1.326	2.07	1.374	2.22	1.464	2.42	1.534	2.65	17
18	1.047	1.063	1.125	1.141	1.389	2.14	1.437	2.28	1.527	2.49	1.597	2.71	18
19	1.109	1.126	1.188	1.203	1.452	2.20	1.500	2.34	1.590	2.55	1.660	2.78	19
20	1.172	1.189	1.250	1.266	1.514	2.26	1.562	2.40	1.652	2.61	1.722	2.84	20
21	1.234	1.251	1.312	1.328	1.576	2.32	1.624	2.47	1.714	2.67	1.784	2.90	21
22	1.297	1.313	1.375	1.391	1.639	2.39	1.687	2.53	1.777	2.74	1.847	2.96	22
23	1.359	1.376	1.438	1.453	1.702	2.45	1.750	2.59	1.840	2.80	1.910	3.03	23
24	1.422	1.439	1.500	1.516	1.764	2.51	1.812	2.65	1.902	2.86	1.972	3.09	24
25	1.484	1.501	1.562	1.578	1.826	2.57	1.874	2.72	1.964	2.92	2.034	3.15	25
26	1.547	1.563	1.625	1.641	1.889	2.64	1.937	2.78	2.027	2.99	2.097	3.21	26
27	1.609	1.626	1.688	1.703	1.952	2.70	2.000	2.84	2.090	3.05	2.160	3.28	27
28	1.672	1.689	1.750	1.766	2.014	2.76	2.062	2.90	2.152	3.11	2.222	3.34	28
29	1.734	1.751	1.812	1.828	2.076	2.82	2.124	2.97	2.214	3.17	2.284	3.40	29
30	1.797	1.813	1.875	1.891	2.139	2.89	2.187	3.03	2.277	3.24	2.347	3.47	30
31	1.859	1.876	1.938	1.953	2.202	2.95	2.250	3.09	2.340	3.30	2.410	3.53	31
32	1.922	1.939	2.000	2.016	2.264	3.01	2.312	3.15	2.402	3.36	2.472	3.59	32

MECHANICAL PROPERTIES

GP PIN PART NUMBER	PIN NOM. SIZE	MINIMUM DOUBLE SHEAR POUNDS	COLLAR PART NUMBER	MINIMUM ULTIMATE TENSILE LBS. WITH 2TC-M/2TCC-M COLLARS	PIN POSITION SWAGE GAGE
GPL7TP-EU06	.190	5380	2TC-M06 2TCC-M06	2750	HG134-06
GPL7TP-EU08	.250	9300	2TC-M08 2TCC-M08	5000	HG134-08
GPL7TP-EU10	.312	14600	2TC-M10 2TCC-M10	8300	HG134-10
GPL7TP-EU12	.375	21000	2TC-M12 2TCC-M12	12700	HG134-12

ALL DATA ARE ROOM TEMPERATURE VALUES

DIMENSIONS IN INCHES.

ISSUED 11-16-84

REVISED 12/19/85

SHEET 2 OF 2

GROOVE PROPORTIONED (GP) PIN,
SWAGE LOCKING, STANDARD DIAMETER - PULL-TYPE
TENSION, PROTRUDING HEAD,
A286 CRES. (95 KSI SHEAR)

GPL7TP-EU

PAGE NO. SK 12348

REVISION 4-3-85 UPDATED COMPLETELY. REVISION 7-22-85 COLUMN "Z" REVISED. REVISION 12/19/85 ADDED SWAGE GAGE CALLOUT.

THIS DRAWING, THE STRUCTURAL DESIGN DISCLOSED THEREIN, AND THE TECHNICAL DATA AND ENGINEERING SPECIFICATIONS REPRESENTED THEREBY ARE THE EXCLUSIVE PROPERTY OF THE HUCK MANUFACTURING COMPANY.