

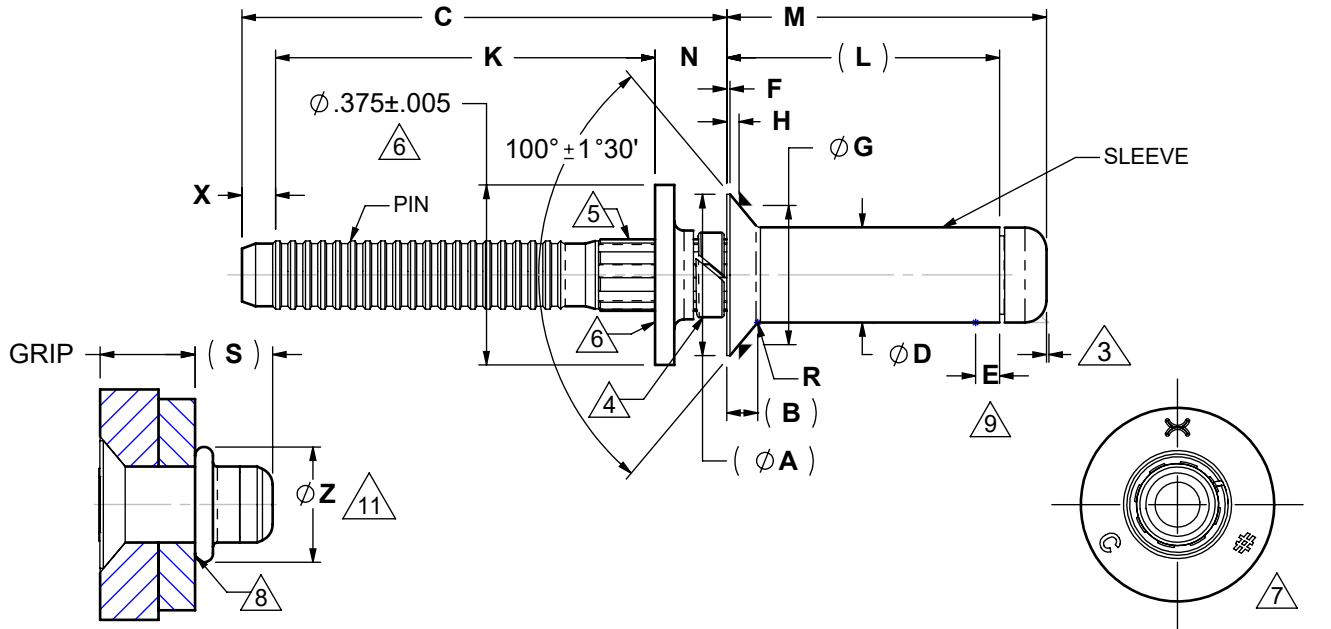

HOWMET FASTENING SYSTEMS
TUCSON OPERATIONS
3724 EAST COLUMBIA STREET
TUCSON, ARIZONA 85714
PHONE (520) 519-7400
FAX (520) 519-7454

Unimatic®
ADVANCED BLIND BOLT
ENGINEERING
STANDARD



INSTALLED FASTENER

TABLE I

VIEW WITHOUT DRIVE WASHER

DIA. DASH NO.	(Ø A) HEAD THEO.	(B) HEAD HEIGHT	C MIN	Ø D ±.001	E MAX	F MAX	Ø G GAGE ±.0001	H GAGE HEIGHT	K ±.030	N ±.060	R RAD MAX	(S)	X ±.030	Ø Z MIN.	SINGLE SHEAR STRENGTH LBS	TENSILE STRENGTH LBS	SPINDLE RET. LBS	HOLE SIZE +.003 - .000
							$\triangle 10$	$\triangle 10$						$\triangle 11$	$\triangle 1$ $\triangle 2$	$\triangle 1$		
-05	.290	.052	.844	.163	.300	.010	.2559	.0138 .0108	.800	.140	.010	.232	.060	.223	1980	1050	525	.164
-06	.357	.065	.875	.198	.320	.010	.3173	.0160 .0130	.830	.160	.015	.292	.070	.270	2925	1500	750	.199
-08	.480	.091	1.000	.259	.370	.012	.4319	.0205 .0165	.975	.190	.020	.361	.090	.355	5000	2600	1300	.260

- $\triangle 1$. MINIMUM ULTIMATE SINGLE SHEAR AND TENSILE STRENGTHS, IN POUNDS, OF INSTALLED FASTENER.
- $\triangle 2$. APPLIES TO GRIPS 05-04 MAX, 06-05 MAX, AND 08-06 MAX AND GREATER. IN SHORTER GRIPS, A TRUE COMPOSITE SHEAR TEST CANNOT BE PERFORMED.
- $\triangle 3$. TRIM FLASH NOT TO EXCEED .005 MAXIMUM LENGTH ABOVE HEAD OF PIN.
- $\triangle 4$. SOLID OR SPLIT LOCK COLLAR AT MANUFACTURER'S OPTION.
- $\triangle 5$. KNURLED TO RETAIN FASTENER ASSEMBLY. NOT PART OF INSTALLED FASTENER.
- $\triangle 6$. DRIVE WASHER TO FACILITATE INSTALLATION ONLY. NOT PART OF INSTALLED FASTENER. -05 DIA SIZE ALSO AVAILABLE WITH REDUCED O.D. DRIVE ANVIL OF .312 ± .005, SEE PART NUMBER EXAMPLES.
- $\triangle 7$. IDENTIFICATION: HUCK SYMBOL, "C" FOR MATERIAL AND GRIP DASH NUMBER.
- $\triangle 8$. BLIND SIDE HEAD MAY BE INSTALLED ON 7° MAXIMUM SLOPE.
- $\triangle 9$. SLEEVE DIAMETER "D" MAY BE .002 UNDERSIZE IN THIS AREA.
- $\triangle 10$. FOR EQUIVALENT GAGE HEIGHTS SEE TABLE IV, SHEET 2.

DIMENSIONS IN INCHES

AC	PER ECN 15394, REMOVED "THIS IS APPLICABLE TO DESIGN GRIP RANGE" FROM NOTE 11.	Current Design Activity CAGE Code 0HDW7	PROCUREMENT SPEC T0106	DRAWN BY J. SCHLOBOHM
			CHECKED BY	SIGNATURE ON FILE
ISSUED	12/8/2001	Unimatic® ADVANCED SERIES BLIND BOLT FASTENER, HIGH STRENGTH, PULL-TYPE, POSITIVE MECHANICAL LOCK, 100° FLUSH HEAD (MS20426), A-286 CRES (95 KSI SHEAR) SINGLE ACTION INSTALLATION. LARGE FOOT PRINT		UAB6127-EU
REVISED	07/12/2023			SK12770
PAGE	1 OF 3			

THIS DRAWING, THE STRUCTURAL DESIGN DISCLOSED THEREIN AND THE TECHNICAL DATA AND ENGINEERING SERVICE REPRESENTED THEREBY ARE THE EXCLUSIVE PROPERTY OF HUCK INTERNATIONAL, INC.

This drawing/documentation is controlled by either the Department of State, International Traffic In Arms Regulations or the Department of Commerce, Export Administration Regulations and may require an export license/license exception prior to being transferred to a foreign national, inside or outside of the United States. EAR/ECCN EAR99. These commodities, technology or software were exported from the United States in accordance with the Export Administration Regulations. Diversion contrary to U.S. law prohibited.



HOWMET FASTENING SYSTEMS
TUCSON OPERATIONS
3724 EAST COLUMBIA STREET
TUCSON, ARIZONA 85714
PHONE (520) 519-7400
FAX (520) 519-7454

Unimatic®
ADVANCED BLIND BOLT
ENGINEERING
STANDARD

THIS DRAWING, THE STRUCTURAL DESIGN DISCLOSED THEREIN AND THE TECHNICAL DATA AND ENGINEERING SERVICE REPRESENTED THEREBY ARE THE EXCLUSIVE PROPERTY OF HUCK INTERNATIONAL, INC.

11 THE AVERAGE READING OF THE SMALLEST & LARGEST OBSERVED VALUE ON THE SAME SPECIMEN MUST BE EQUAL TO OR GREATER THAN THE STATED MINIMUM DIAMETER.

12 OVERLAP MIN. GRIP FOR -.06 DIA IS .140 AND FOR -.08 DIA IS NONE.

TABLE II

GRIP NUMBER TABULATION															
GRIP DASH NO.	OVERLAP GRIP MIN 05 DIA	DESIGN GRIP RANGE		OVERLAP GRIP MAX 05 DIA	05		GRIP DASH NO.	OVERLAP GRIP MIN 06 & 08 DIA	DESIGN GRIP RANGE 06 & 08 DIA.		OVERLAP GRIP MAX 6 & 8 DIA	06		08	
		MIN.	MAX.		(L)	M MAX			MIN.	MAX.		(L)	M MAX	(L)	M MAX
02	NONE	.094	.157	.173	.336	.476	02	NONE	.120	.157	.173	.355	.521		
03	.146	.156	.220	.236	.398	.539	03	12	.156	.220	.236	.417	.584	.479	.645
04	.209	.219	.282	.298	.460	.602	04	.203	.219	.282	.298	.480	.647	.541	.708
05	.271	.281	.345	.361	.523	.664	05	.265	.281	.345	.361	.542	.709	.604	.770
06	.334	.344	.407	.423	.585	.727	06	.328	.344	.407	.423	.605	.772	.666	.833
07	.396	.406	.470	.486	.648	.789	07	.390	.406	.470	.486	.667	.834	.729	.895
08	.459	.469	.532	.548	.710	.852	08	.453	.469	.532	.548	.730	.897	.791	.958
09	.521	.531	.595	.611	.773	.914	09	.515	.531	.595	.611	.792	.959	.854	1.020
10	.584	.594	.657	.673	.835	.977	10	.578	.594	.657	.673	.855	1.022	.916	1.083
11	.646	.656	.720	.736	.898	1.039	11	.640	.656	.720	.736	.917	1.084	.979	1.145
12	.709	.719	.782	.798	.960	1.102	12	.703	.719	.782	.798	.980	1.147	1.041	1.208
13	.771	.781	.845	.861	1.023	1.164	13	.765	.781	.845	.861	1.042	1.209	1.104	1.271
14	.834	.844	.907	.923	1.085	1.227	14	.828	.844	.907	.923	1.105	1.272	1.166	1.333
15	.896	.906	.970	.986	1.148	1.289	15	.890	.906	.970	.986	1.167	1.334	1.229	1.396
16	.959	.969	1.032	1.048	1.210	1.352	16	.953	.969	1.032	1.048	1.230	1.397	1.291	1.458
							17	1.018	1.031	1.095	1.111	1.292	1.459	1.354	1.521
							18	1.078	1.094	1.157	1.173	1.355	1.522	1.416	1.583
							19	1.141	1.156	1.220	1.236	1.417	1.584	1.479	1.646
							20	1.203	1.219	1.282	1.298	1.480	1.647	1.541	1.708

TABLE III

UAB6127 INSTALLED WEIGHT IN LBS (1000 pcs.)				UAB6127 INSTALLED WEIGHT IN LBS (1000 pcs.)			
GRIP	5 DIA	6 DIA	8 DIA	GRIP	5 DIA	6 DIA	8 DIA
02	2.23	3.65		12	5.89	9.02	16.99
03	2.56	4.07	8.62	13	6.26	9.57	17.92
04	2.93	4.62	9.55	14	6.63	10.12	18.85
05	3.30	5.17	10.48	15	7.00	10.67	19.78
06	3.67	5.72	11.41	16	7.37	11.22	20.71
07	4.04	6.27	12.34	17		11.77	21.64
08	4.41	6.82	13.27	18		12.32	22.57
09	4.78	7.37	14.20	19		12.87	23.50
10	5.15	7.92	15.13	20		13.42	24.43
11	5.52	8.47	16.06				

TABLE IV

EQUIVALENT GAGE HEIGHTS		
DIA	Ø G GAGE ±.0001	H GAGE HEIGHT
-05	.2340	.0230 .0200
-06	.2840	.0300 .0270
-08	.3854	.0400 .0360

DIMENSIONS IN INCHES

AC	PER ECN 15394, REMOVED "THIS IS APPLICABLE TO DESIGN GRIP RANGE" FROM NOTE 11.	Current Design Activity	PROCUREMENT SPEC T0106	DRAWN BY J. SCHLOBOHM
		CAGE Code 0HDW7		CHECKED BY SIGNATURE ON FILE
ISSUED	12/8/2001	Unimatic® ADVANCED SERIES BLIND BOLT FASTENER, HIGH STRENGTH, PULL-TYPE, POSITIVE MECHANICAL LOCK, 100° FLUSH HEAD (MS20426), A-286 CRES (95 KSI SHEAR) SINGLE ACTION INSTALLATION. LARGE FOOT PRINT		UAB6127-EU
REVISED	07/12/2023			SK12770
PAGE	2 OF 3			



HOWMET FASTENING SYSTEMS
TUCSON OPERATIONS
3724 EAST COLUMBIA STREET
TUCSON, ARIZONA 85714
PHONE (520) 519-7400
FAX (520) 519-7454

Unimatic®
ADVANCED BLIND BOLT
ENGINEERING
STANDARD

TABLE V

FINISH CODE	MATERIAL ¹⁴			FINISH			LUBE ¹³
	SLEEVE	PIN	LOCK COLLAR	SLEEVE	PIN	LOCK COLLAR	
NONE	A-286 CRES AMS 5737	A-286 CRES AMS 5737	A-286 CRES AMS 5737 OR 316 CRES AMS5690	PASSIVATE AMS2700 & AMS-QQ-P-35	PASSIVATE AMS2700 & AMS-QQ-P-35	PASSIVATE AMS2700 & AMS-QQ-P-35	OPTIONAL
D	A-286 CRES AMS 5737	A-286 CRES AMS 5737	A-286 CRES AMS 5737 OR 316 CRES AMS5690	ALUMINUM COAT MIL-DTL-83488	PASSIVATE AMS2700 & AMS-QQ-P-35	PASSIVATE AMS2700 & AMS-QQ-P-35	OPTIONAL
CD	A-286 CRES AMS 5737	A-286 CRES AMS 5737	A-286 CRES AMS 5737 OR 316 CRES AMS5690	CAD. PLATE AMS-QQ-P-416 TYPE II CLEAR DICHROMATE CLASS 2	PASSIVATE AMS2700 & AMS-QQ-P-35	PASSIVATE AMS2700 & AMS-QQ-P-35	OPTIONAL
AC ¹⁵	A-286 CRES AMS 5737	A-286 CRES AMS 5737	A-286 CRES AMS 5737 OR 316 CRES AMS5690	ALUMINUM PIGMENTED COATING PER NAS4006 AND BMS 10-85	PASSIVATE AMS2700 & AMS-QQ-P-35	PASSIVATE AMS2700 & AMS-QQ-P-35	OPTIONAL
ACN ¹⁵	A-286 CRES AMS 5737	A-286 CRES AMS 5737	A-286 CRES AMS 5737 OR 316 CRES AMS5690	NON-CHROMATE ALUMINUM PIGMENTED COATING PER NAS4006 AND EN4473	PASSIVATE AMS2700 & AMS-QQ-P-35	PASSIVATE AMS2700 & AMS-QQ-P-35	OPTIONAL

¹³ LUBE AND LOCK COLLAR MATERIAL AT MANUFACTURER'S OPTION. LUBRICATION- WHEN LUBRICATED, PARTS SHALL BE LUBRICATED PER AS5272, AS87132 OR LOX COMPATIBLE DRY FILM LUBRICANT. (MANUFACTURER'S OPTIONS)

¹⁴ MATERIAL REFERS TO CHEMICAL COMPOSITION ONLY.

¹⁵ COMPLETE COVERAGE OF SLEEVE INTERNAL FEATURES IS NOT REQUIRED. OVER SPRAY ONTO THE INTERNAL FEATURES IS ACCEPTIBLE.

PART NUMBER
UAB6127-EU06-06 (*) R

CODE "R" FOR REDUCED DRIVE ANVIL DIAMETER ON -.05 DIA SIZE ONLY.
FINISH CODE - SEE TABLE V I.
GRIP NUMBER IN 16th INCHES.
NOMINAL SHANK DIAMETER IN 32nd INCHES.
Unimatic® ADVANCED SERIES BLIND BOLT FASTENER, HIGH STRENGTH PULL-TYPE,
A286 CRES MATERIAL, POSITIVE MECHANICAL LOCK, 100° FLUSH HEAD (MS20426),
EXPANDED BULB. LARGE FOOT PRINT. DRIVE WASHER INCLUDED.

DIMENSIONS IN INCHES

AC	PER ECN 15394, REMOVED "THIS IS APPLICABLE TO DESIGN GRIP RANGE" FROM NOTE 11.	Current Design Activity CAGE Code 0HDW7	PROCUREMENT SPEC T0106	DRAWN BY J. SCHLOBOHM
				CHECKED BY SIGNATURE ON FILE
ISSUED	12/8/2001	Unimatic® ADVANCED SERIES BLIND BOLT FASTENER, HIGH STRENGTH, PULL-TYPE, POSITIVE MECHANICAL LOCK, 100° FLUSH HEAD (MS20426), A-286 CRES (95 KSI SHEAR) SINGLE ACTION INSTALLATION. LARGE FOOT PRINT		UAB6127-EU
REVISED	07/12/2023			SK12770
PAGE	3 OF 3			

THIS DRAWING, THE STRUCTURAL DESIGN DISCLOSED THEREIN AND THE TECHNICAL DATA AND ENGINEERING SERVICE REPRESENTED THEREBY ARE THE EXCLUSIVE PROPERTY OF HUCK INTERNATIONAL, INC.