



HOWMET FASTENING SYSTEMS
 TUCSON OPERATIONS
 3724 EAST COLUMBIA STREET
 TUCSON, ARIZONA 85714
 PHONE (520) 519-7400
 FAX (520) 519-7454

TI-MATIC®
**ENGINEERING
 STANDARD**

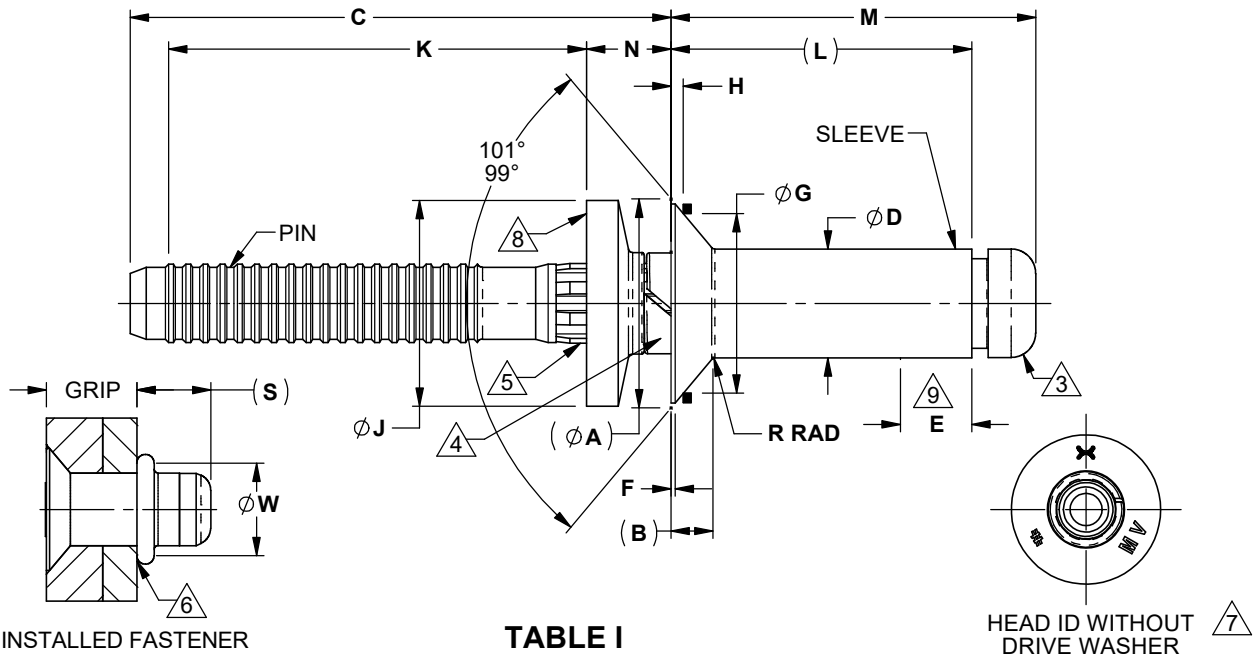

TABLE I

NOM. DIA.	(Ø A) HEAD THEO. INTER REF	(B) HEAD HEIGHT REF	C MIN	Ø D ±.001	E MAX ⁹	F MAX	Ø G GAGE ±.0001	H GAGE HEIGHT	Ø J ±.005 ¹	K ±.030	N ±.060	R RAD MAX	(S) DESIGN REF ONLY	Ø W MIN	SINGLE SHEAR ²	TENSILE STRENGTH
-05	.333	.072	.844	.163	.300	.011	.2831	.0206 .0171	.375	.800	.140	.010	.232	.228	1980	900
-06	.386	.080	.875	.198	.320	.013	.3271	.0243 .0205		.830	.160	.015	.292	.277	2925	1400
-08	.507	.105	1.000	.259	.370	.017	.4319	.0310 .0270		.975	.190	.020	.361	.363	5000	2100

- ¹ -05 DIA SIZE ALSO AVAILABLE WITH REDUCED O.D. DRIVE ANVIL OF .312 ±.005. (SEE SHEET 3)
- ² APPLIES TO GRIPS 05-04 MAX, 06-05 MAX, 08-06 MAX AND GREATER. IN SHORTER GRIPS, A TRUE COMPOSITE SHEAR TEST CANNOT BE PERFORMED.
- ³ TRIM FLASH NOT TO EXCEED .005" MAXIMUM LENGTH ABOVE HEAD OF PIN.
- ⁴ SOLID OR SPLIT LOCK COLLAR AT MANUFACTURER'S OPTION. SPLIT NOT TO EXCEED .020 WIDTH.
- ⁵ KNURLED TO RETAIN FASTENER ASSEMBLY. NOT PART OF INSTALLED FASTENER.
- ⁶ BLIND SIDE HEAD MAY BE INSTALLED ON 7° MAX SLOPE.
- ⁷ IDENTIFICATION: HUCK SYMBOL, MV (FOR CP TITANIUM SLEEVE MATERIAL) AND GRIP DASH NUMBER.
- ⁸ OPTIONAL DRIVE WASHER FOR INSTALLATION WITH BLUNT TOOL. NOT PART OF INSTALLED FASTENER.
- ⁹ SLEEVE DIAMETER "D" MAY BE .002" UNDERSIZED IN THIS AREA.

DIMENSIONS IN INCHES

P	PER ECN 16070, ACN SUFFIX IS NOW OBSOLETE; THE AC SUFFIX NOW INDICATES NON-CHROMATED COATING		Current Design Activity CAGE Code 0HDW7	PROC. SPEC. T0106	DRAWN BY J. SCHLOBOHM	CHECKED BY SIGNATURE ON FILE
	ISSUED	12/31/2001	UNIMATIC® BLIND BOLT FASTENER, HIGH STRENGTH, PULL-TYPE, POSITIVE MECHANICAL LOCK, 100° FLUSH HEAD, LARGE FOOTPRINT, TITANIUM/TITANIUM (95 KSI SHEAR), SINGLE ACTION INSTALLATION			UAB100-MV
	REVISD	5/23/2025				SK12772
PAGE	1 OF 3					

This drawing/documentation is controlled by either the Department of State, International Traffic In Arms Regulations or the Department of Commerce, Export Administration Regulations and may require an export license/exception prior to being transferred to a foreign national, inside or outside of the United States. EAR/ECCN 9A991. These commodities, technology or software were exported from the United States in accordance with the Export Administration Regulations. Diversion contrary to U.S. law prohibited.

THIS DRAWING, THE STRUCTURAL DESIGN DISCLOSED THEREIN AND THE TECHNICAL DATA AND ENGINEERING SERVICE REPRESENTED THEREBY ARE THE EXCLUSIVE PROPERTY OF HUCK INTERNATIONAL, INC.



HOWMET FASTENING SYSTEMS
 TUCSON OPERATIONS
 3724 EAST COLUMBIA STREET
 TUCSON, ARIZONA 85714
 PHONE (520) 519-7400
 FAX (520) 519-7454

TI-MATIC®
ENGINEERING
STANDARD

△ OVERLAP MINIMUM GRIP FOR -.06 DIAMETER IS .140, FOR -.08 DIAMETER IS NONE.

TABLE II



GRIP NUMBER TABULATION															
GRIP DASH NO.	OVERLAP GRIP MIN	DESIGN GRIP RANGE		OVERLAP GRIP MAX	05		GRIP DASH NO.	OVERLAP GRIP MIN	DESIGN GRIP RANGE		OVERLAP GRIP MAX	06		08	
		MIN.	MAX.		(L)	M MAX			MIN.	MAX.		(L)	M MAX	(L)	M MAX
02	NONE	.094	.157	.173	.336	.476	02	NONE	.120	.157	.173	.355	.521	-	-
03	.146	.156	.220	.236	.398	.539	03	NOTE 10	.156	.220	.236	.417	.583	.479	.645
04	.209	.219	.282	.298	.460	.602	04	.203	.219	.282	.298	.480	.646	.541	.707
05	.271	.281	.345	.361	.523	.664	05	.265	.281	.345	.361	.542	.708	.604	.770
06	.334	.344	.407	.423	.585	.727	06	.328	.344	.407	.423	.605	.771	.666	.832
07	.396	.406	.470	.486	.648	.789	07	.390	.406	.470	.486	.667	.833	.729	.895
08	.459	.469	.532	.548	.710	.852	08	.453	.469	.532	.548	.730	.896	.791	.957
09	.521	.531	.595	.611	.773	.914	09	.515	.531	.595	.611	.792	.958	.854	1.020
10	.584	.594	.657	.673	.835	.977	10	.578	.594	.657	.673	.855	1.021	.916	1.082
11	.646	.656	.720	.735	.898	1.039	11	.640	.656	.720	.736	.917	1.083	.979	1.145
12	.709	.719	.782	.798	.960	1.102	12	.703	.719	.782	.798	.980	1.146	1.041	1.207
13	.771	.781	.845	.860	1.023	1.164	13	.765	.781	.845	.861	1.042	1.208	1.104	1.270
14	.834	.844	.907	.923	1.085	1.227	14	.828	.844	.907	.923	1.105	1.271	1.166	1.332
15	.896	.906	.970	.985	1.148	1.289	15	.890	.906	.970	.986	1.167	1.333	1.229	1.395
16	.959	.969	1.032	1.048	1.210	1.352	16	.953	.969	1.032	1.048	1.230	1.396	1.291	1.457
17	-	-	-	-	-	-	17	1.015	1.031	1.095	1.111	-	-	1.354	1.520
18	-	-	-	-	-	-	18	1.078	1.094	1.157	1.173	-	-	1.416	1.582
19	-	-	-	-	-	-	19	1.140	1.156	1.220	1.236	-	-	1.479	1.645
20	-	-	-	-	-	-	20	1.203	1.219	1.282	1.298	-	-	1.541	1.707

TABLE III

UAB100-MV INSTALLED WEIGHT IN LBS (1000 pcs.)											
GRIP	5 DIA	6 DIA	8 DIA	GRIP	5 DIA	6 DIA	8 DIA	GRIP	5 DIA	6 DIA	8 DIA
-02	1.53	2.48	5.43	-09	3.04	4.64	8.73	-15	4.36	6.62	12.04
-03	1.72	2.67	5.43	-10	3.26	4.97	9.28	-16	4.58	6.95	12.59
-04	1.94	2.99	5.97	-11	3.48	5.30	9.83	-17	-	-	13.15
-05	2.16	3.32	6.52	-12	3.70	5.63	10.38	-18	-	-	13.70
-06	2.38	3.65	7.07	-13	3.92	5.96	10.94	-19	-	-	14.25
-07	2.60	3.98	7.62	-14	4.14	6.29	11.49	-20	-	-	14.80
-08	2.82	4.31	8.18								

DIMENSIONS IN INCHES

P	PER ECN 16070, ACN SUFFIX IS NOW OBSOLETE; THE AC SUFFIX NOW INDICATES NON-CHROMATED COATING		Current Design Activity CAGE Code 0HDW7	PROC. SPEC. T0106	DRAWN BY J. SCHLOBOHM
					CHECKED BY SIGNATURE ON FILE
	ISSUED REVISD PAGE	12/31/2001 5/23/2025 2 OF 3	UNIMATIC® BLIND BOLT FASTENER, HIGH STRENGTH, PULL-TYPE, POSITIVE MECHANICAL LOCK, 100° FLUSH HEAD, LARGE FOOTPRINT, TITANIUM/TITANIUM (95 KSI SHEAR), SINGLE ACTION INSTALLATION		

THIS DRAWING, THE STRUCTURAL DESIGN DISCLOSED THEREIN AND THE TECHNICAL DATA AND ENGINEERING SERVICE REPRESENTED THEREBY ARE THE EXCLUSIVE PROPERTY OF HUCK INTERNATIONAL, INC.

This drawing/documentation is controlled by either the Department of State, International Traffic in Arms Regulations or the Department of Commerce, Export Administration Regulations and may require an export license/exception prior to being transferred to a foreign national, inside or outside of the United States. EAR/ECCN 9A991. These commodities, technology or software were exported from the United States in accordance with the Export Administration Regulations. Diversion contrary to U.S. law prohibited.



HOWMET FASTENING SYSTEMS
 TUCSON OPERATIONS
 3724 EAST COLUMBIA STREET
 TUCSON, ARIZONA 85714
 PHONE (520) 519-7400
 FAX (520) 519-7454

TI-MATIC®
**ENGINEERING
 STANDARD**

TABLE IV

FINISH CODE	MATERIAL			FINISH			LUBE
	SLEEVE	PIN	LOCK COLLAR	SLEEVE	PIN	LOCK COLLAR	
NONE	CP TITANIUM PER ASTM-B348	38-6-44 TITANIUM PER AMS 4957	A-286 CRES PER AMS 5737	NONE	NONE	PASSIVATE PER AMS QQ-P-35 AND AMS2700	△12
DF	CP TITANIUM PER ASTM-B348	38-6-44 TITANIUM PER AMS 4957	A-286 CRES PER AMS 5737	NONE	NONE	PASSIVATE PER AMS QQ-P-35 AND AMS2700	△13
AC △14.	CP TITANIUM PER ASTM-B348	38-6-44 TITANIUM PER AMS 4957	A-286 CRES PER AMS 5737	NON-CHROMATE ALUMINUM PIGMENTED COATING PER NAS4006 AND EN4473	NONE	PASSIVATE PER AMS QQ-P-35 AND AMS2700	△12
AT	CP TITANIUM PER ASTM-B348	38-6-44 TITANIUM PER AMS 4957	A-286 CRES PER AMS 5737	BLUE ANODIZE PER ISO 8080	NONE	PASSIVATE PER AMS QQ-P-35 AND AMS2700	△12

△11. LUBE AND LOCK COLLAR MATERIAL AT MANUFACTURER'S OPTION.

△12. LUBRICATION: SERRATED PIN: NONE OR CETYL ALCOHOL (CHLORINE FREE) PER AS87132 TYPE 1 OR DRY FILM LUBE PER AS5272 AT MANUFACTURER'S OPTION.
 MECHANICAL LOCK: NONE OR LOX COMPATIBLE DRY FILM LUBE AT MANUFACTURER'S OPTION.
 SLEEVE : NO SUFFIX AND AC SUFFIX: NONE OR CETYL ALCOHOL (CHLORINE FREE) PER AS87132 TYPE 1 OR DRY FILM LUBE PER AS5272 AT MANUFACTURER'S OPTION.

△13. DF SUFFIX PARTS WHEN LUBED SHALL USE AS5272 ON ANY OF THE FASTENER COMPONENTS EXCEPT MECHANICAL LOCK MAY USE LOX COMPATIBLE DRY FILM LUBE (MFG'S OPTION)

△14. COMPLETE COVERAGE OF SLEEVE INTERNAL FEATURES IS NOT REQUIRED. OVER SPRAY ONTO THE INTERNAL FEATURES IS ACCEPTABLE

PART NUMBER
 UAB100-MV06 -06 (*)R

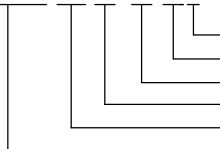

R - DENOTES REDUCED DRIVE ANVIL DIAMETER ON -05 DIA SIZE ONLY
 FINISH CODE - SEE TABLE V
 GRIP NUMBER IN 1/16" INCREMENTS.
 NOMINAL SHANK DIAMETER IN 32nd INCHES.
 MATERIAL DESIGNATOR - TITANIUM/TITANIUM.
 UNIMATIC® BLIND BOLT FASTENER, HIGH STRENGTH PULL-TYPE,
 POSITIVE MECHANICAL LOCK, 100° FLUSH HEAD, EXPANDED BULB,
 LARGE FOOTPRINT, DRIVE WASHER INCLUDED

DIMENSIONS IN INCHES

P	PER ECN 16070, ACN SUFFIX IS NOW OBSOLETE; THE AC SUFFIX NOW INDICATES NON-CHROMATED COATING		Current Design Activity CAGE Code 0HDW7	PROC. SPEC. T0106	DRAWN BY J. SCHLOBOHM
	ISSUED	12/31/2001	UNIMATIC® BLIND BOLT FASTENER, HIGH STRENGTH, PULL-TYPE, POSITIVE MECHANICAL LOCK, 100° FLUSH HEAD, LARGE FOOTPRINT, TITANIUM/TITANIUM (95 KSI SHEAR), SINGLE ACTION INSTALLATION		CHECKED BY SIGNATURE ON FILE
	REVISD	5/23/2025			UAB100-MV
PAGE	3 OF 3			SK12772	

This drawing/documentation is controlled by either the Department of State, International Traffic in Arms Regulations or the Department of Commerce, Export Administration Regulations and may require an export license/exception prior to being transferred to a foreign national, inside or outside of the United States. EAR/ECCN 9A991. These commodities, technology or software were exported from the United States in accordance with the Export Administration Regulations. Diversion contrary to U.S. law prohibited.

THIS DRAWING, THE STRUCTURAL DESIGN DISCLOSED THEREIN AND THE TECHNICAL DATA AND ENGINEERING SERVICE REPRESENTED THEREBY ARE THE EXCLUSIVE PROPERTY OF HUCK INTERNATIONAL, INC.