

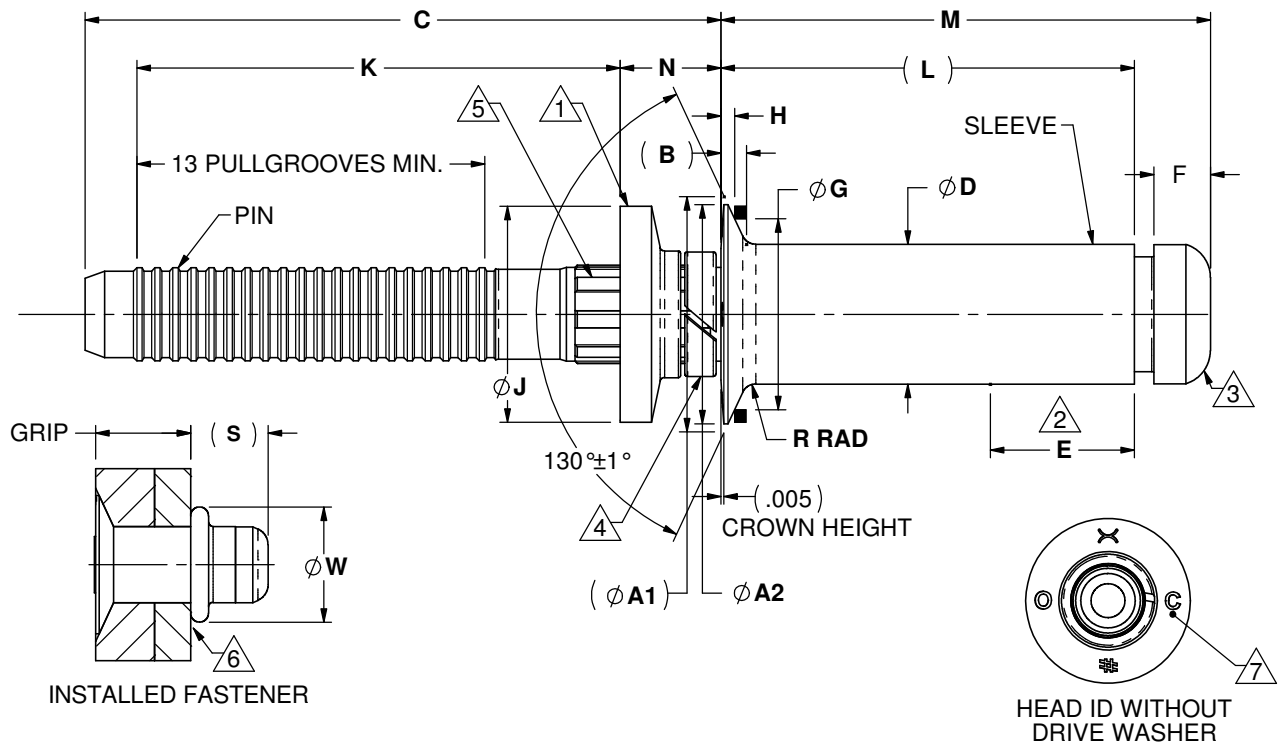

Howmet Fastening Systems  
Tucson Operations  
3724 East Columbia Street  
Tucson, Arizona 85714 USA  
Phone (520) 519-7400  
Fax (520) 519-7454

**Unimatic®**  
**ADVANCED BLIND BOLT**  
**ENGINEERING**  
**STANDARD**



**TABLE I**

PART NUMBER	O/S DIA	(Ø A1) THEO REF	Ø A2 MIN	(B) HEAD HEIGHT REF	C MIN	Ø D SLEEVE ±.001	E MAX	F	Ø G GAGE	H GAGE HEIGHT	Ø J ±.005	K ±.030	N ±.060	R RAD MAX	(S) MAX REF	Ø W MIN	HOLE LIMITS +.003 - .000
OUAB130-EU07-( )	07	.416	.373	.043	.925	.242	.350	.103 .093	.3315 .3313	.0247 .0221	.375	.890	.175	.030	.303	.327	.244
OUAB130-EU09-( )	09	.538	.494	.057	1.100	.304	.430	.128 .118	.4320 .4318	.0297 .0274		1.050	.210	.030	.349	.411	.306
OUAB130-EU10-( )	10	.635	.577	.075	1.100	.326	.475	.139 .125	.5389 .5385	.0277 .0251	.438	1.050	.240	.040	.386	.441	.328

- 1. DRIVE WASHER TO FACILITATE INSTALLATION ONLY. NOT PART OF THE INSTALLED FASTENER.
- 2. "E" LENGTH OF "ØD" MAY BE .002 UNDERSIZE.
- 3. TRIM FLASH NOT TO EXCEED .005 MAXIMUM LENGTH ABOVE HEAD OF PIN.
- 4. SOLID OR SPLIT LOCK COLLAR - MANUFACTURER'S OPTION. SPLIT NOT TO EXCEED .020 WIDTH.
- 5. KNURLED TO FACILITATE FASTENER ASSEMBLY. NOT PART OF THE INSTALLED FASTENER.
- 6. BLIND SIDE HEAD MAY BE INSTALLED ON 7° MAXIMUM SLOPE.
- 7. IDENTIFICATION: HUCK SYMBOL, "O", "C" (MATERIAL) AND GRIP DASH NUMBER.
- 8. MINIMUM ULTIMATE SINGLE SHEAR AND TENSILE STRENGTHS IN POUNDS OF INSTALLED FASTENER.
- 9. SINGLE SHEAR APPLIES TO GRIPS 07-05 MAX, 09-07 MAX, 10-07 MAX AND UP. IN SHORTER GRIPS, A TRUE COMPOSITE SHEAR TEST CANNOT BE OBTAINED.

DIMENSIONS IN INCHES

<b>E</b>	PER ECN 14571 EXT GRIPS CHANGED TO MATCH EN6122 STDS		Current Design Activity CAGE Code OHDW7		PROCUREMENT SPEC T0106	DRAWN BY J. SCHLOBOHM
					CHECKED BY	SIGNATURE ON FILE
ISSUED	3/2/2015	OVERSIZE Unimatic ADVANCED SERIES BLIND BOLT FASTENER, HIGH STRENGTH, PULL-TYPE, POSITIVE MECHANICAL LOCK, 130° FLUSH HEAD, INTERMEDIATE SHANK DIAMETER, LARGE FOOT PRINT, A-286 CRES (95 KSI SHEAR) SINGLE ACTION INSTALLATION				<b>OUAB130-EU</b>
REVISED	07-24-20					<b>SK12949</b>
PAGE	1 OF 3					

This drawing/documentation is controlled by either the Department of State, International Traffic In Arms Regulations or the Department of Commerce, Export Administration Regulations and may Require an export license/license exception prior to being transferred to a foreign national, inside or outside of the United States. EAR/ECCN EAR99. These commodities, technology or software were exported from the United States in accordance with the Export Administration Regulations. Diversion contrary to U.S. law prohibited.

THIS DRAWING, THE STRUCTURAL DESIGN DISCLOSED THEREIN AND THE TECHNICAL DATA AND ENGINEERING SERVICE REPRESENTED THEREBY ARE THE EXCLUSIVE PROPERTY OF HUCK INTERNATIONAL, INC.



Howmet Fastening Systems  
 Tucson Operations  
 3724 East Columbia Street  
 Tucson, Arizona 85714 USA  
 Phone (520) 519-7400  
 Fax (520) 519-7454

**Unimatic®**  
**ADVANCED BLIND BOLT**  
**ENGINEERING**  
**STANDARD**

**TABLE II**

GRIP NUMBER TABULATION						
GRIP DASH NUMBER	OVERLAP GRIP MIN	DESIGN GRIP RANGE		OVERLAP GRIP MAX	07	
		MIN	MAX		( L )	M MAX
-03	NONE	.156	.220	.236	.484	.645
-04	.203	.219	.282	.298	.531	.692
-05	.265	.281	.345	.361	.593	.754
-06	.328	.344	.407	.423	.656	.817
-07	.390	.406	.470	.486	.718	.879
-08	.453	.469	.532	.548	.781	.942
-09	.515	.531	.595	.611	.843	1.004
-10	.578	.594	.657	.673	.906	1.067
-11	.640	.656	.720	.735	.968	1.129
-12	.703	.719	.782	.798	1.031	1.192
-13	.765	.781	.845	.860	1.093	1.254
-14	.828	.844	.907	.923	1.156	1.317
-15	.890	.906	.970	.985	1.218	1.379
-16	.953	.969	1.032	1.048	1.281	1.442
-17	1.015	1.031	1.095	1.111	1.343	1.504
-18	1.078	1.094	1.157	1.173	1.406	1.567
-19	1.140	1.156	1.220	1.236	1.468	1.629
-20	1.203	1.219	1.282	1.298	1.531	1.692

**TABLE II (CONT'D)**

GRIP NUMBER TABULATION						
GRIP DASH NUMBER	DESIGN GRIP RANGE		09		10	
	MIN	MAX	( L )	M MAX	( L )	M MAX
-03	.156	.220	.538	.724	-	-
-04	.219	.282	.585	.771	.608	.805
-05	.281	.345	.647	.833	.671	.868
-06	.344	.407	.710	.896	.733	.930
-07	.406	.470	.772	.958	.796	.993
-08	.469	.532	.835	1.021	.858	1.055
-09	.531	.595	.897	1.083	.921	1.118
-10	.594	.657	.960	1.146	.983	1.180
-11	.656	.720	1.022	1.208	1.046	1.243
-12	.719	.782	1.085	1.271	1.108	1.305
-13	.781	.845	1.147	1.333	1.171	1.368
-14	.844	.907	1.210	1.396	1.233	1.430
-15	.906	.970	1.272	1.458	1.296	1.493
-16	.969	1.032	1.335	1.521	1.358	1.555
-17	1.031	1.095	1.397	1.583	1.421	1.618
-18	1.094	1.157	1.460	1.646	1.483	1.680
-19	1.156	1.220	1.522	1.708	1.546	1.743
-20	1.219	1.282	1.585	1.771	1.608	1.805

DIMENSIONS IN INCHES

<b>E</b>	PER ECN 14571 EXT GRIPS CHANGED TO MATCH EN6122 STDS		Current Design Activity CAGE Code OHDW7		PROCUREMENT SPEC T0106	DRAWN BY J. SCHLOBOHM	
	ISSUED 3/2/2015	OVERSIZE Unimatic ADVANCED SERIES BLIND BOLT FASTENER, HIGH STRENGTH, PULL-TYPE, POSITIVE MECHANICAL LOCK, 130° FLUSH HEAD, INTERMEDIATE SHANK DIAMETER, LARGE FOOT PRINT, A-286 CRES (95 KSI SHEAR) SINGLE ACTION INSTALLATION				CHECKED BY	SIGNATURE ON FILE
	REVISID 07-24-20					<b>OUB130-EU</b>	
PAGE 2 OF 3					<b>SK12949</b>		

This drawing/documentation is controlled by either the Department of State, International Traffic In Arms Regulations or the Department of Commerce, Export Administration Regulations and may Require an export license/license exception prior to being transferred to a foreign national, inside or outside of the United States. EAR/ECCN EAR99. These commodities, technology or software were exported from the United States in accordance with the Export Administration Regulations. Diversion contrary to U.S. law prohibited.

THIS DRAWING, THE STRUCTURAL DESIGN DISCLOSED THEREIN AND THE TECHNICAL DATA AND ENGINEERING SERVICE REPRESENTED THEREBY ARE THE EXCLUSIVE PROPERTY OF HUCK INTERNATIONAL, INC.

E



Howmet Fastening Systems  
 Tucson Operations  
 3724 East Columbia Street  
 Tucson, Arizona 85714 USA  
 Phone (520) 519-7400  
 Fax (520) 519-7454

**Unimatic®**  
**ADVANCED BLIND BOLT**  
**ENGINEERING**  
**STANDARD**

**TABLE III**

OUAB130-EU INSTALLED WEIGHT IN LBS (1000 pcs.)											
GRIP	7 DIA	9 DIA	10 DIA	GRIP	7 DIA	9 DIA	10 DIA	GRIP	7 DIA	9 DIA	10 DIA
-03	6.65	12.25		-09	11.37	19.67	23.91	-15	16.29	27.41	32.82
-04	7.27	13.22	16.49	-10	12.19	20.96	25.40	-16	17.11	28.70	34.31
-05	8.09	14.51	17.97	-11	13.01	22.25	26.88	-17	17.93	29.99	35.79
-06	8.91	15.80	19.46	-12	13.83	23.54	28.37	-18	18.75	31.28	37.28
-07	9.73	17.09	20.94	-13	14.65	24.83	29.85	-19	19.57	32.57	38.76
-08	10.55	18.38	22.43	-14	15.47	26.12	31.34	-20	20.39	33.86	40.25

**TABLE IV**

PART NUMBER	O/S DIA	SINGLE SHEAR (lbs)	TENSILE (lbs)	TENSILE PRELOAD (lbs)	SPINDLE RET (lbs)
OUAB130-EU07-( )	07	3830	1990	199	975
OUAB130-EU09-( )	09	6210	3225	323	1600
OUAB130-EU10-( )	10	7200	3750	375	1875

**TABLE V**

FINISH CODE	MATERIAL			FINISH			LUBE
	SLEEVE	PIN	LOCK COLLAR	SLEEVE	PIN	LOCK COLLAR	
NONE	A-286 CRES AMS 5737	A-286 CRES AMS 5737	A-286 CRES AMS 5737 OR 316 CRES AMS5690	PASSIVATE AMS2700	PASSIVATE AMS2700	PASSIVATE AMS2700	OPTIONAL
AC	A-286 CRES AMS 5737	A-286 CRES AMS 5737	A-286 CRES AMS 5737 OR 316 CRES AMS5690	ALUMINUM COAT PER NAS4006, BMS 10-85 & EN4473	PASSIVATE AMS2700	PASSIVATE AMS2700	OPTIONAL
NC	A-286 CRES AMS 5737	A-286 CRES AMS 5737	A-286 CRES AMS 5737 OR 316 CRES AMS5690	ALUMINUM COAT PER EN4473, TYPE II OR IV	PASSIVATE AMS2700	PASSIVATE AMS2700	OPTIONAL

LUBRICATION- WHEN LUBRICATED, PARTS SHALL BE LUBRICATED PER AS5272, AS87132 OR LOX COMPATIBLE DRY FILM LUBRICANT. (MANUFACTURER'S OPTIONS)

HUCK PART NUMBER EXAMPLE:

OUAB130-EU07 - 04( )

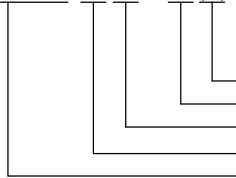

FINISH CODE - SEE TABLE  
 GRIP NUMBER IN 16th INCHES.  
 NOMINAL SHANK DIAMETER IN 32nd INCHES.  
 MATERIAL DESIGNATOR - A286.  
 OVERSIZE Unimatic® ADVANCED SERIES BLIND BOLT FASTENER, HIGH STRENGTH PULL-TYPE, POSITIVE MECHANICAL LOCK, 130° FLUSH HEAD, INTERMEDIATE SHANK DIAMETER, EXPANDED BULB. LARGE FOOT PRINT. DRIVE WASHER INCLUDED.

DIMENSIONS IN INCHES

E	PER ECN 14571 EXT GRIPS CHANGED TO MATCH EN6122 STDS		Current Design Activity CAGE Code OHDW7		PROCUREMENT SPEC T0106	DRAWN BY J. SCHLOBOHM	CHECKED BY SIGNATURE ON FILE	
	ISSUED	3/2/2015	OVERSIZE Unimatic ADVANCED SERIES BLIND BOLT FASTENER, HIGH STRENGTH, PULL-TYPE, POSITIVE MECHANICAL LOCK, 130° FLUSH HEAD, INTERMEDIATE SHANK DIAMETER, LARGE FOOT PRINT, A-286 CRES (95 KSI SHEAR) SINGLE ACTION INSTALLATION				<b>OUAB130-EU</b>	
	REVISID	07-24-20					<b>SK12949</b>	
PAGE	3 OF 3							

This drawing/documentation is controlled by either the Department of State, International Traffic In Arms Regulations or the Department of Commerce, Export Administration Regulations and may Require an export license/license exception prior to being transferred to a foreign national, inside or outside of the United States. EAR/ECCN EAR99. These commodities, technology or software were exported from the United States in accordance with the Export Administration Regulations. Diversion contrary to U.S. law prohibited.

THIS DRAWING, THE STRUCTURAL DESIGN DISCLOSED THEREIN AND THE TECHNICAL DATA AND ENGINEERING SERVICE REPRESENTED THEREBY ARE THE EXCLUSIVE PROPERTY OF HUCK INTERNATIONAL, INC.